

Operation Manual

Rotavapor® R-80



Imprint

Product Identification:
Operation Manual (Original) Rotavapor® R-80
11594485

Publication date: 03.2024

Version A

BÜCHI Labortechnik AG
Meierseggrasse 40
Postfach
CH-9230 Flawil 1
E-Mail: quality@buchi.com

BÜCHI reserves the right to make changes to the manual as deemed necessary in the light of experience, especially with respect to structure, illustrations and technical details.

This manual is copyrighted. Information from it may neither be reproduced, distributed, or used for competitive purposes, nor made available to third parties. The manufacture of any component with the aid of this manual without prior written agreement is also prohibited.

Table of contents

1	About this document.....	6
1.1	Mark-ups and symbols.....	6
1.2	Trademarks.....	6
1.3	Connected instruments.....	6
2	Safety	7
2.1	Intended use	7
2.2	Use other than that intended	7
2.3	Staff qualification	7
2.4	Personal protective equipment	8
2.5	Warning notices in this document.....	8
2.6	Warning symbols	8
2.7	Residual risks	9
2.7.1	Faults during operation	9
2.7.2	Dangerous vapors.....	9
2.7.3	Dangerous particles	10
2.7.4	Glass breakage.....	10
2.7.5	High internal pressure.....	10
2.7.6	Hot surfaces and liquids.....	10
2.7.7	Rotating parts.....	10
2.8	Modifications.....	10
3	Product description.....	12
3.1	Description of function	12
3.1.1	Distillation under vacuum	12
3.2	Configuration	13
3.2.1	Front view	13
3.2.2	Rear view	14
3.2.3	Connections	15
3.3	Scope of delivery	16
3.4	Type plate.....	16
3.5	Technical data	16
3.5.1	Rotavapor® R-80	16
3.5.2	Ambient conditions.....	17
3.5.3	Materials	17
3.5.4	Installation site	18
4	Transport and storage.....	19
4.1	Transport	19
4.2	Storage	19
4.3	Lifting the instrument	19

5	Installation	20
5.1	Overview.....	20
5.2	Before installation.....	21
5.3	Installing the Rotavapor®.....	21
5.4	Installing the vacuum pump.....	22
5.5	Installing the Interface I-80 / I-180.....	22
5.6	Installing the Woulff bottle.....	22
5.7	Connecting vacuum.....	23
5.7.1	Connecting the vacuum pump.....	23
5.8	Connecting the cooling.....	25
5.9	Accessories.....	25
5.9.1	Connecting the cooling water temperature sensor.....	25
5.9.2	Connecting the cooling water valve.....	27
5.10	Securing against earthquakes.....	27
5.11	Establishing electrical connections.....	27
6	Interface	29
6.1	Configuration.....	29
6.2	Display layout.....	29
6.3	Display symbols.....	30
6.4	Main functions.....	30
6.4.1	Start/Stop heating and cooling.....	30
6.4.2	Control rotation speed.....	31
6.4.3	Stop the instrument.....	31
6.5	Settings.....	31
6.5.1	Operation settings.....	31
6.5.2	Setting to default settings.....	32
6.6	Advanced settings.....	32
7	Operation	34
7.1	Preparing the heating bath.....	34
7.1.1	Filling the heating bath.....	34
7.1.2	Positioning the heating bath.....	34
7.2	Attaching the evaporating flask.....	34
7.3	Attaching the receiving flask.....	35
7.4	Adjusting immersion angle of evaporating flask.....	36
7.5	Adjusting immersion depth of evaporating flask.....	36
7.6	Using the height adjustment stopper.....	37
7.7	Performing a distillation process.....	38
7.8	Performing a drying process.....	39
7.9	Aerating the system.....	40
7.10	Removing the evaporating flask.....	41
7.11	Removing the receiving flask.....	42

8	Cleaning and servicing	43
8.1	Maintenance work.....	43
8.2	Removing solvent accumulations	43
8.3	Cleaning the housing.....	44
8.4	Cleaning and servicing the warning and directive symbols	44
8.5	Cleaning the heating bath.....	44
8.6	Cleaning the condenser.....	44
8.7	Cleaning the Woulff bottle.....	45
8.8	Inspecting and replacing the seals	45
8.9	Inspecting and replacing the hoses	45
8.10	Inspecting and cleaning the vapor duct	45
8.11	Performing a leak test.....	46
	8.11.1 Performing a leak test manually.....	46
	8.11.2 Performing the leak test with the Interface I-180	47
9	Help with faults	48
9.1	Troubleshooting	48
	9.1.1 Error codes	50
	9.1.2 Customer service	51
9.2	Resetting overheat safety cut-out.....	52
10	Taking out of service and disposal.....	53
10.1	Taking out of service.....	53
10.2	Disposal	53
10.3	Returning the instrument	53
11	Appendix	54
11.1	Spare parts and accessories	54
	11.1.1 Spare parts	54
	11.1.2 Wear parts	56
	11.1.3 Glass parts.....	57
	11.1.4 Accessories.....	61

1 About this document

This operation manual is applicable for all variants of the instrument.

Read this operation manual before operating the instrument and follow the instructions to ensure safe and trouble-free operation.

Keep this operation manual for later use and pass it on to any subsequent user or owner.

BÜCHI Labortechnik AG accepts no liability for damage, faults and malfunctions resulting from not following this operation manual.

If you have any questions after reading this operation manual:

- ▶ Contact BÜCHI Labortechnik AG Customer Service.

<https://www.buchi.com/contact>

1.1 Mark-ups and symbols



NOTE

This symbol draws attention to useful and important information.

- ☑ This character draws attention to a requirement that must be met before the instructions below are carried out.
- ▶ This character indicates an instruction that must be carried out by the user.
- ⇒ This character indicates the result of a correctly carried out instruction.

Mark-up	Explanation
<i>Window</i>	Software Windows are marked-up like this.
<i>Tab</i>	Tabs are marked-up like this.
<i>Dialog</i>	Dialogs are marked-up like this.
<i>[Button]</i>	Buttons are marked-up like this.
<i>[Field names]</i>	Field names are marked-up like this.
<i>[Menu / Menu item]</i>	Menus or menu items are marked-up like this.
Status	Status is marked-up like this.
Signal	Signals are marked-up like this.

1.2 Trademarks

Product names and registered or unregistered trademarks that are used in this document are used only for identification and remain the property of the owner in each case.

1.3 Connected instruments

In addition to this operation manual, follow the instructions and specifications in the documentation for the connected instruments.

2 Safety

2.1 Intended use

The instrument is designed for rotary evaporation.

The instrument can be used in laboratories and production for the following tasks:

- Evaporating solvents
- Synthesis of chemicals
- Purification of chemicals
- Concentration of solvents
- Recycling of solvents
- Recrystallization
- Drying of powders and granulates

2.2 Use other than that intended

Use of any kind other than that described in the section Chapter 2.1 "Intended use", page 7 and any application that does not comply with the technical specifications (see Chapter 3.5 "Technical data", page 16) constitutes use other than that intended.

In particular, the following applications are not permissible:

- Use of the device in an environment with a potential risk of explosion or areas which require explosion-safe apparatus
- Use of the device for processing substances in the food, animal feed or cosmetics industries
- Use of fluids in the heating bath which are not specified in the technical data. (e.g. oil).
- Production and processing of substances that can lead to spontaneous reactions, e.g. explosives, metal hydrides or solvents that can form peroxides
- Working with explosive gas mixtures
- Drying hard, brittle substances (e.g. stone or soil samples) that could damage the evaporating flask
- Shock-cooling of the evaporating flask or other glass components

Damage or hazards attributable to use of the product other than as intended are entirely at the risk of the user alone.

2.3 Staff qualification

Unqualified persons are unable to identify risks and are therefore exposed to greater dangers.

The instrument must be operated by suitably qualified laboratory staff.

The instrument must be commissioned and serviced by suitably qualified technicians.

These operating instructions are aimed at the following target groups:

Users

The users are persons that meet the following criteria:

- They have been instructed in the use of the instrument.
- They are familiar with the contents of these operating instructions and the applicable safety regulations and apply them.
- They are able, on the basis of their training or professional experience, to assess the risks associated with the use of the instrument.

Operator

The operator (generally the laboratory manager and qualified technicians) are responsible for the following aspects:

- The instrument must be correctly installed, commissioned, operated and serviced.
- Only suitably qualified staff must be assigned the task of performing the operations described in these operating instructions.
- The staff must comply with the local applicable requirements and regulations for safe and hazard-conscious working practices.
- Safety-related incidents that occur while using the instrument should be reported to the manufacturer (quality@buchicom).

BUCHI service technicians

Service technicians authorized by BUCHI have attended special training courses and are authorized by BÜCHI Labortechnik AG to carry out special servicing and repair measures.

2.4 Personal protective equipment

Depending on the application, hazards due to heat and/or corrosive chemicals may arise.

- ▶ Always wear appropriate personal protective equipment such as safety goggles, protective clothing and gloves.
- ▶ Make sure that the personal protective equipment meets the requirements of the safety data sheets for all chemicals used.



2.5 Warning notices in this document

Warning notices warn you of dangers that can occur when handling the instrument. There are four danger levels, each identifiable by the signal word used.

Signal word	Meaning
DANGER	Indicates a danger with a high level of risk which could result in death or serious injury if not prevented.
WARNING	Indicates a danger with a medium level of risk which could result in death or serious injury if not prevented.
CAUTION	Indicates a danger with a low level of risk which could result in minor or medium-severity injury if not prevented.
NOTICE	Indicates a danger that could result in damage to property.

2.6 Warning symbols

The following warning symbols are displayed in this operation manual or on the instrument.

Symbol	Meaning
	General warning
	Instrument damage
	Dangerous electrical voltage

Symbol	Meaning
	Hot surface

Location of the warning symbols on the instrument

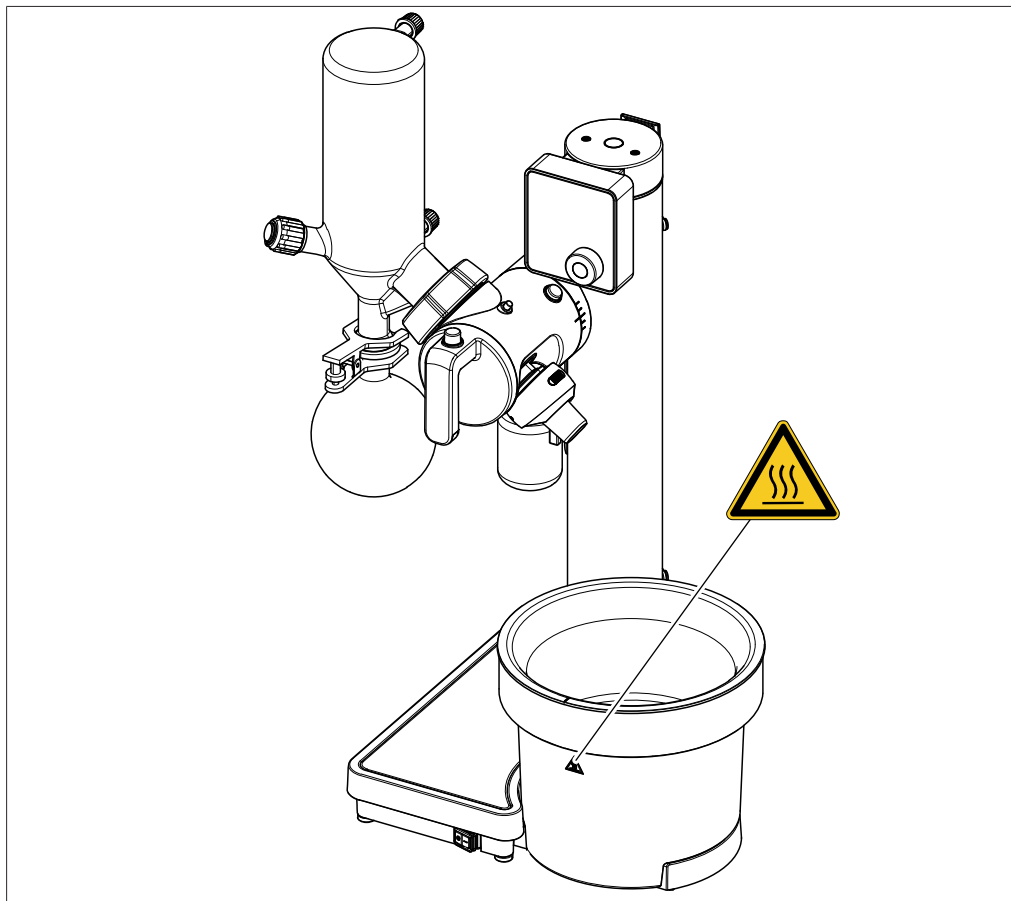

2.7 Residual risks

The instrument has been developed and manufactured using the latest technological advances. Nevertheless, risks to persons, property or the environment can arise if the instrument is used incorrectly.

Appropriate warnings in this manual serve to alert the user to these residual dangers.

2.7.1 Faults during operation

If an instrument is damaged, sharp edges, glass splinters, moving parts or exposed electrical wires can cause injuries.

- ▶ Regularly check instruments for visible damage.
- ▶ If faults occur, switch off the instrument immediately, unplug the power cord and inform the operator.
- ▶ Do not continue to use instruments that are damaged.

2.7.2 Dangerous vapors

The use of the instrument can produce dangerous vapors that are capable of causing life-threatening toxic effects.

- ▶ Do not inhale any vapors produced during processing.
- ▶ Ensure that vapors are removed by a suitable fume hood.
- ▶ Only use the instrument in well ventilated areas.

- ▶ If vapors escape from connections, check the seals concerned and replace them if necessary.
- ▶ Do not process any unknown fluids.
- ▶ Observe the safety data sheets for all substances used.

2.7.3 Dangerous particles

The use of the instrument can produce dangerous particles that can cause life-threatening toxic effects.

- ▶ Observe the safety data sheets for all substances used.
- ▶ Do not process any unknown substances.
- ▶ Do not inhale any particles produced during processing.
- ▶ Ensure that particles are removed by a suitable fume hood.
- ▶ Only use the instrument in well ventilated areas.
- ▶ If particles escape from connections, check the seals concerned and replace them if necessary.

2.7.4 Glass breakage

Broken glass can cause severe cuts.

Damaged glass components may implode if subjected to a vacuum.

Minor damage to the ground joints impairs the sealing effect and may therefore diminish performance.

- ▶ Handle the flask and other glass components carefully and do not drop them.
- ▶ Always visually inspect glass components for damage every time they are to be used.
- ▶ Do not continue to use glass components that are damaged.
- ▶ Always wear protective gloves when disposing of broken glass.

2.7.5 High internal pressure

The evaporation of fluids can produce high pressures inside the flask or the condenser. If that pressure becomes too great, the glass components could explode.

- ▶ Make sure that the internal pressure inside the glass components is never greater than atmospheric pressure.
- ▶ When distilling without a vacuum, set the vacuum pump to atmospheric pressure so that excess pressure is automatically dissipated.
- ▶ If a vacuum pump is not used, leave the vacuum connection open.

2.7.6 Hot surfaces and liquids

The heating bath, evaporating flask and parts of the condenser can become very hot. If touched they can cause skin burns.

- ▶ Do not touch hot surfaces or liquids or else wear suitable protective gloves.

2.7.7 Rotating parts

The evaporating flask and the vapor duct are rotated by the rotary drive unit. Hair, clothing or jewelry can become caught up if allowed to come into contact with the rotating parts.

At high speeds, the heating fluid may be sprayed out by the rotation of the evaporating flask.

- ▶ Wear work overalls or protective clothing.
- ▶ Do not wear loose or baggy items of clothing such as scarves or neck-ties.
- ▶ Tie up long hair.
- ▶ Do not wear jewelry such as necklaces or bracelets.

2.8 Modifications

Unauthorized modifications can affect safety and lead to accidents.

- ▶ Use only genuine BUCHI accessories, spare parts and consumables.

- ▶ Carry out technical changes only with prior written approval from BUCHI.
- ▶ Only allow changes to be made by BUCHI service technicians.

BUCHI accepts no liability for damage, faults and malfunctions resulting from unauthorized modifications.

3 Product description

3.1 Description of function

The instrument is a rotary evaporator with the aid of which a single-stage distillation can be carried out quickly without unduly stressing the product. The basis of the process is the evaporation and condensation of solvents using a rotating evaporating flask under vacuum.

- The product is heated in the evaporating flask by the heating bath.
- The rotary drive unit evenly rotates the evaporating flask.
 - The rotation increases the surface area of the liquid which leads to an increased evaporation rate.
 - The rotation constantly mixes the product which can prevent local overheating and boiling retardation.
- The vapor passes from the evaporating flask through the vapor duct into the cooling section.
- In the cooling section, the thermal energy of the vapor is transferred to the coolant so that the vapor condenses.
- The condensed solvent is collected in the receiving flask and can then be reused or properly disposed of.

3.1.1 Distillation under vacuum

Distillation capacity depends on the following factors:

- Temperature of the heating bath
- Pressure in the system
- Rotation speed of the evaporating flask
- Size and wall thickness of the evaporating flask
- Cooling temperature and cooling capacity of the coolant

Pressure in the evaporating flask:

A low pressure (below atmospheric) reduces the boiling point of the solvent. A lower boiling point means the solvent does not have to be heated as much. Distillation under vacuum is more efficient and gentler on the product.

Vacuum control:

A stable vacuum adapted to the application prevents undesirable solvent emissions and bumping (boiling retardation) of the product.

Heating bath temperature, coolant temperature and vapor temperature:

To ensure an optimal distillation, it is important to make sure that the temperature difference between the coolant and the heating bath is at least 40 °C. The temperature of the rising vapor should be midway between the heating bath temperature and the coolant temperature.

3.2 Configuration

3.2.1 Front view

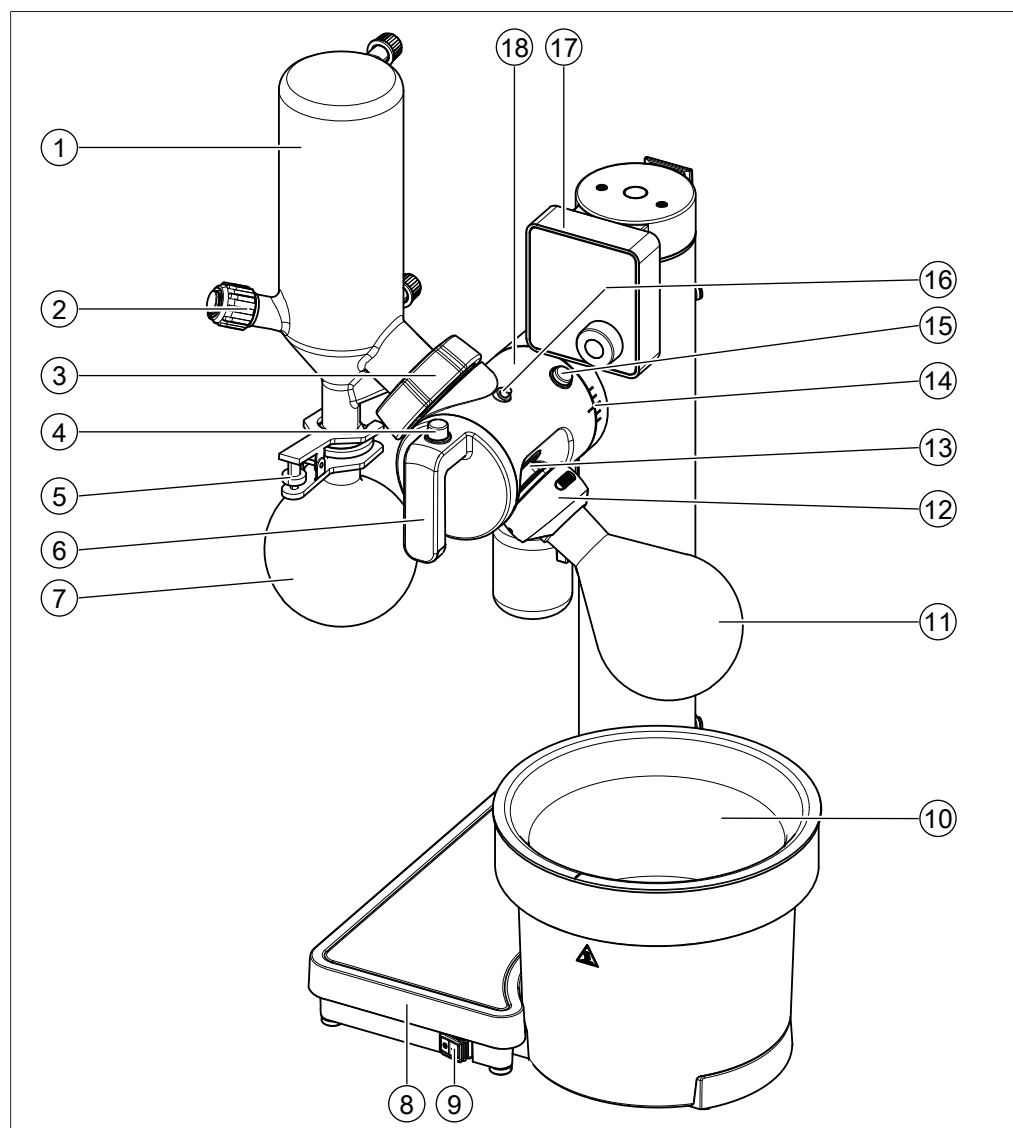

- | | | | |
|----|--------------------------------|----|---|
| 1 | Condenser | 2 | Aeration cap |
| 3 | Flange nut | 4 | Height adjustment button |
| 5 | Ball joint clamp | 6 | Height adjustment handle |
| 7 | Receiving flask | 8 | Base |
| 9 | Main switch | 10 | Heating bath |
| 11 | Evaporating flask | 12 | Combi-Clip |
| 13 | Rotary drive | 14 | Angle adjustment scale |
| 15 | Angle adjustment button | 16 | Locking button for rotary drive unit |
| 17 | Interface | 18 | Rotary drive arm |

3.2.2 Rear view

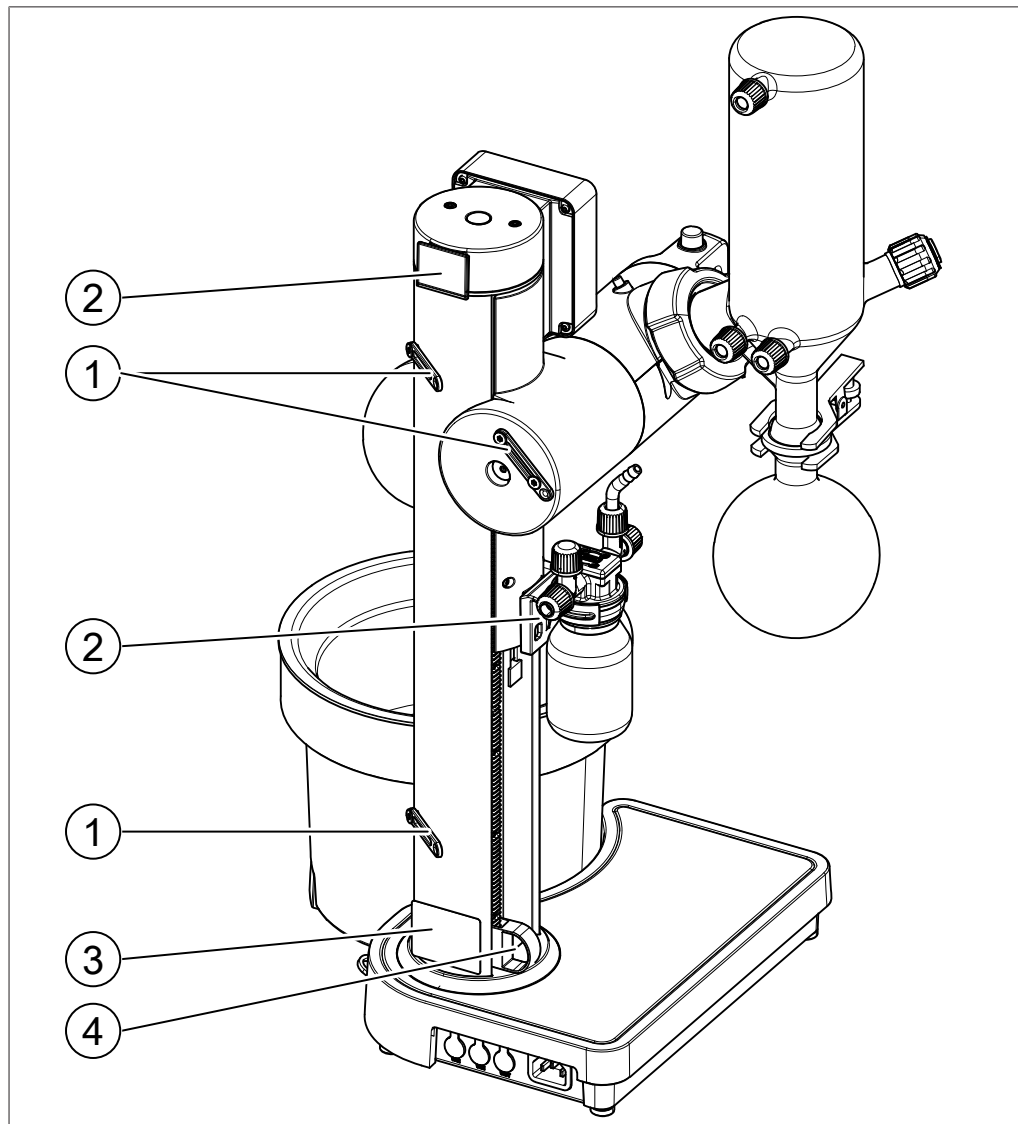

- 1 Cable and tubing fixture
- 3 Type plate

- 2 Woulff bottle attachment
- 4 Height adjustment stopper

3.2.3 Connections

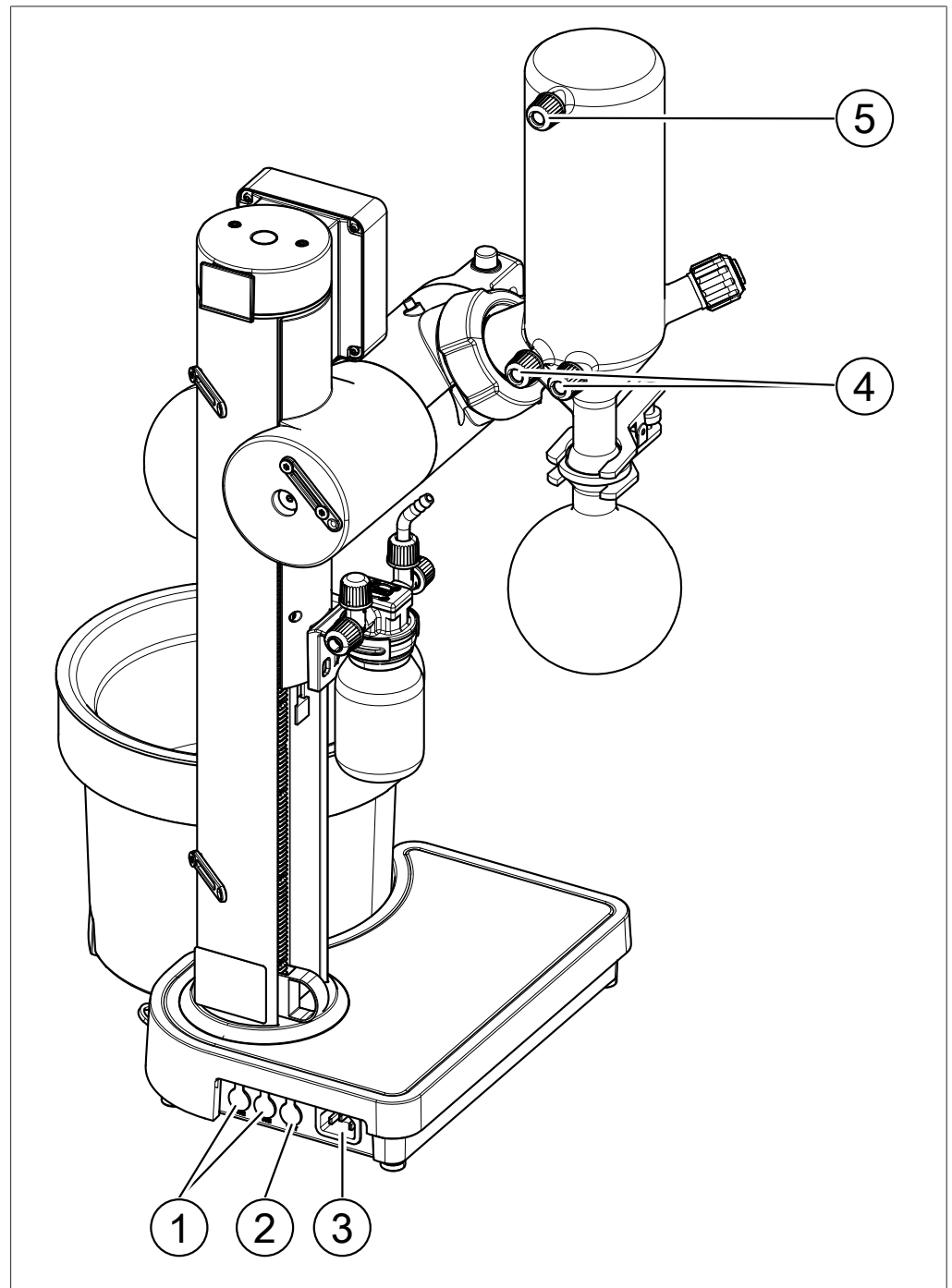

1 Communication **COM**

3 Power supply

5 Vacuum

2 Cooling water valve/temperature sensor **CW/T**

4 Cooling fluid

3.3 Scope of delivery



NOTE

The scope of delivery depends on the configuration of the purchase order.

Accessories are delivered as per the purchase order, order confirmation, and delivery note.

3.4 Type plate

The type plate identifies the instrument. The following type plate is an example. For more details refer to the type plate on the instrument.

The type plate is located at the rear of the instrument.

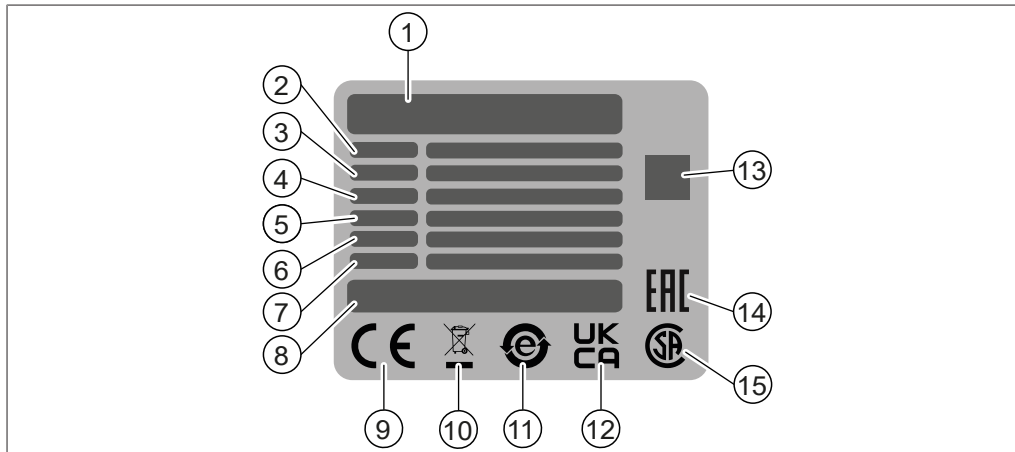

- | | | | |
|----|---|----|---|
| 1 | Company name and address | 2 | Instrument name |
| 3 | Serial number | 4 | Input voltage range |
| 5 | Frequency | 6 | Power consumption maximum |
| 7 | Year of manufacture | 8 | Product origin |
| 9 | Symbol for "CE conformity" | 10 | Symbol for "Do not dispose of as household waste" |
| 11 | Symbol for "electronics recycling" | 12 | Symbol for "UK Conformity Assessed" |
| 13 | QR-Code contains "Item number, Serial number" | 14 | Symbol for "Eurasian Conformity" (optional) |
| 15 | Symbol for "CSA certified" (optional) | | |

3.5 Technical data

3.5.1 Rotavapor® R-80

Specification	Value
Dimensions (W × D × H)	345 mm × 315 mm × 590 mm
Dimensions (W × D × H) with V condenser and power plug	430 mm × 360 mm × 705 mm
Weight with condenser	9 kg
Connection voltage	100 – 120 VAC ± 10% 220 – 240 VAC ± 10%
Frequency	50 / 60 Hz
Power consumption	1,150 W

Specification	Value
Fuse	T 12.5 A H 250 V (100 – 120 V) T 6.3 A H 250 V (220 – 240 V)
Overvoltage category	II
IP Code	IP42
Pollution degree	2
Minimum clearance on all sides	none
Display type	3" Dark segment display
Heating power	1,000 W
High temperature cut-out	140 °C
Heating bath temperature range	Up to 95 °C
Heating bath adjustment accuracy	± 1 °C
Heating bath regulation precision	± 2 °C
Heating bath inner diameter	175 mm
Heating bath capacity	2 L
Heating bath fluid	Water
Typical heating-up time (20°C to 95°C)	14 min
Max. flask size	1,000 mL
Max. flask capacity	800 g
Immersion angle	20 – 50°
Rotation speed range	10 – 330 rpm
Adjustable lift height	180 mm
Cooling surface (V condenser)	1,280 cm ²
Cooling temperature display range	-99 – 99 °C
Certificate	CB, CE, UL / CSA

3.5.2 Ambient conditions

For indoor use only.

Specification	Value
Max. altitude above sea level	2,000 m
Ambient and storage temperature	5 – 40 °C
Max. relative humidity	80% for temperatures up to 31 °C decreasing linearly to 50% relative humidity at 40 °C

3.5.3 Materials

Component	Material
Rotavapor® casing	PBT, aluminium (powder coated)
Heating bath casing	PBT
Heating bath	Polypropylene, stainless steel 1.4404
Rotary drive unit	PBT
Flange connection to condenser	Aluminium (anodized)

In contact with solvents

Component	Material
Vacuum seal	PTFE, NBR
Quick aeration cap (part inside the system)	PTFE
All glass parts	Borosilicate 3.3

3.5.4 Installation site

The installation site must meet the following requirements:

- The installation site meets the safety requirements. See Chapter 2 "Safety", page 7
- The installation site meets the specifications according to the technical data (e.g. weight, dimension, minimum clearance on all sides, etc.). See Chapter 3.5 "Technical data", page 16.
- The installation site has a firm, level and nonslip surface.
- The installation site has no obstacles (e.g. water taps, drains, etc.).
- The installation site has an own mains outlet socket for the instrument.
- The installation site allows that the power supply can be disconnected at any time in case of an emergency.
- The installation site is not exposed to external thermal loads, such as direct solar radiation.
- The installation site has enough space that cables / tubes can be routed safely.
- The installation site has a fume extraction apparatus available or the instrument is set up inside a fume hood when evaporating hazardous chemicals.
- The installation site meets the requirements for the connected devices. See related documentation.

4 Transport and storage

4.1 Transport



NOTICE

Risk of breakage due to incorrect transportation

- ▶ Make sure that the instrument is fully dismantled.
 - ▶ Pack all instrument components properly to prevent breakage. Use the original packaging whenever possible.
 - ▶ Avoid sharp movements during transit.
-
- ▶ After transporting, check the instrument and all glass components for damage.
 - ▶ Damage that has occurred in transit should be reported to the carrier.
 - ▶ Keep packaging for future transportation.

4.2 Storage

- ▶ Make sure that the ambient conditions are complied with (see Chapter 3.5 "Technical data", page 16).
- ▶ Wherever possible, store the instrument in its original packaging.
- ▶ After storage, check the instrument, all glass components, seals and tubing for damage and replace if necessary.

4.3 Lifting the instrument



NOTICE

Dragging the instrument can damage the feet of the instrument.

- ▶ Lift the instrument when positioning or re-locating.
-
- ▶ Lift the instrument at the points indicated.

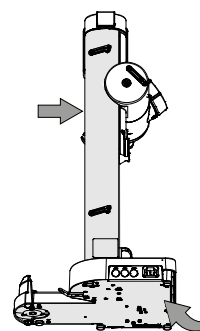

5 Installation

5.1 Overview

Three configurations are available for the Rotavapor® R-80.

- Rotavapor® R-80 standalone
- Rotavapor® R-80 with Vacuum pump V-80 and Interface I-80
- Rotavapor® R-80 with Vacuum pump V-180 and Interface I-180



NOTE

The scope of delivery depends on the configuration of the purchase order.

Accessories are delivered as per the purchase order, order confirmation, and delivery note.

This graphic shows a typical vacuum solution configuration with the corresponding connection. For more details see order code and chapters according to delivered components.

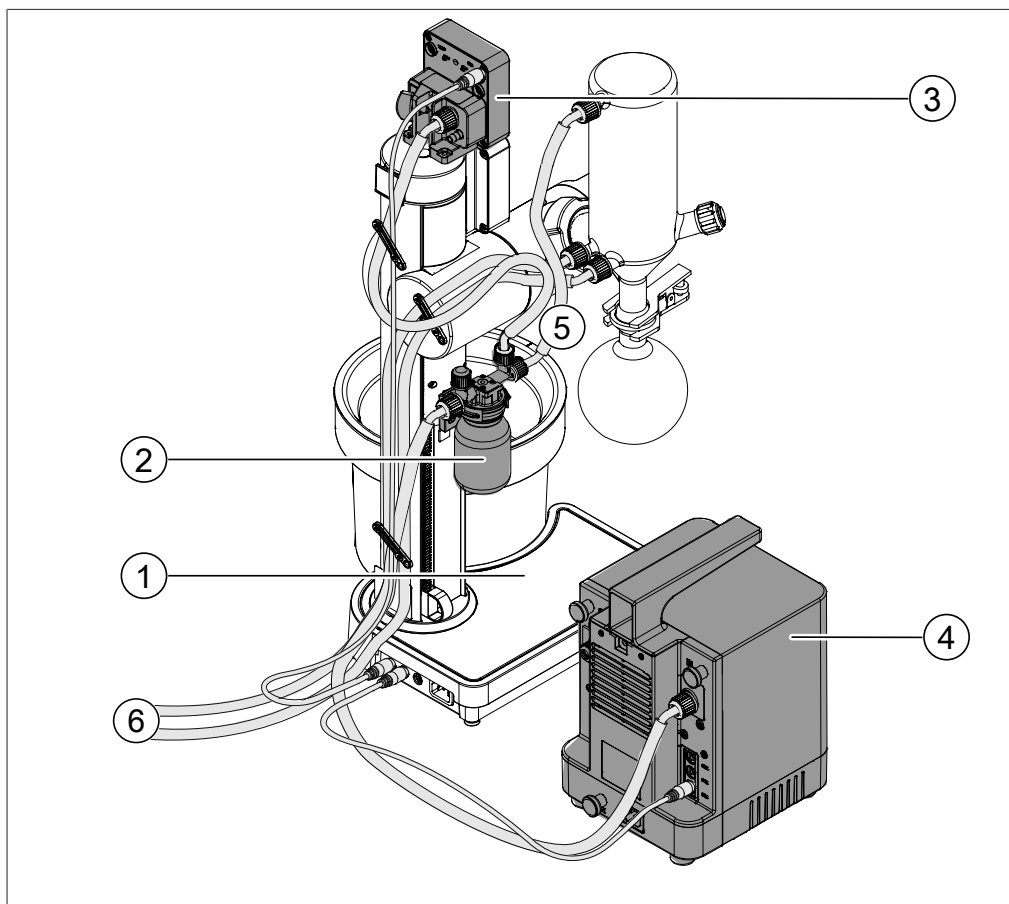

- | | | |
|---|----------------------|---|
| 1 | Rotavapor® | See Chapter 5.3 "Installing the Rotavapor®", page 21. |
| 2 | Woulff bottle | See Chapter 5.6 "Installing the Woulff bottle", page 22. |
| 3 | Interface I-80/I-180 | See Chapter 5.5 "Installing the Interface I-80 / I-180", page 22. |
| 4 | Vacuum pump | See Chapter 5.4 "Installing the vacuum pump", page 22. |

- | | | |
|---|---------------------|--|
| 5 | Vacuum connection | See Chapter 5.7 "Connecting vacuum", page 23.
See additional chapters according to delivered components. |
| 6 | Cooling connections | See Chapter 5.8 "Connecting the cooling", page 25.
See additional chapters according to delivered components. |

5.2 Before installation



NOTICE

Instrument damage due to switching it on too early.

Switching on the instrument too early after transportation can cause damage.

- ▶ Climatize the instrument after transportation.

5.3 Installing the Rotavapor®

- ▶ Insert the vapor duct into the rotary drive unit.
 - ⇒ The vapor duct snaps into place with an audible click.

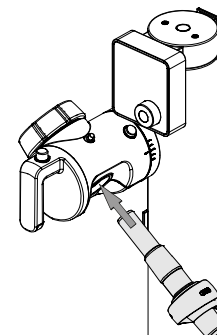

- ▶ Place the vacuum gasket with the inserted adapter on the vapor duct.

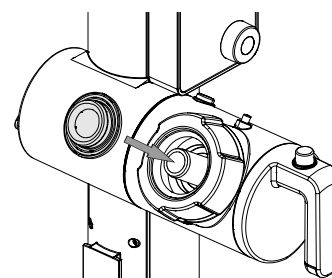

- ▶ Press the vacuum gasket evenly into the flange.
- ▶ Remove the adapter from the vacuum gasket.
 - ⇒ Keep the adapter for later use.
- ▶ Make sure that the vacuum gasket is in the correct position.

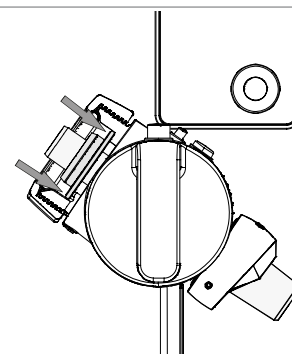

- ▶ Insert the condenser into the flange nut.

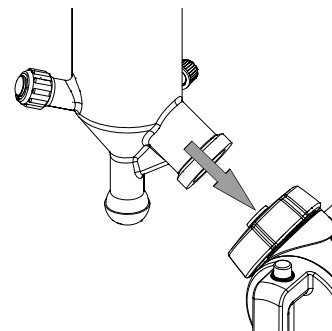

- ▶ Make sure that the spring clip in the flange nut lies around the neck of the condenser.
- ▶ Tighten the flange nut to attach the condenser in position.

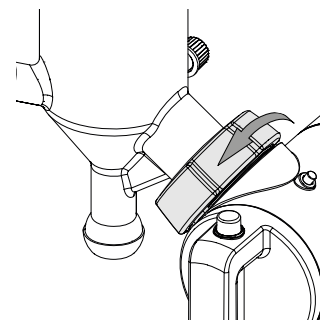

- ▶ Install and connect the instrument. See additional chapters according to delivered components.

5.4 Installing the vacuum pump

- ▶ Installation of the vacuum pump. See additional manual according to purchase order.



5.5 Installing the Interface I-80 / I-180

- ▶ Installation of the Interface I-80 / I-180. See additional manual according to purchase order.



5.6 Installing the Woulff bottle

The Woulff bottle is used to separate out particles and droplets and to equalize pressure.



NOTE

The Woulff bottle can also be installed on the Vacuum Pump. See additional manual according to purchase order.

- ▶ Slide the Woulff bottle holder onto the Woulff bottle attachment.

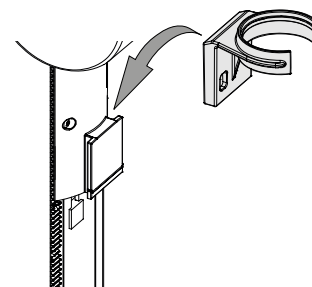

- ▶ Click the Woulff bottle into the Woulff bottle holder.
- ▶ Make sure that the Woulff bottle connection **PUMP** is oriented towards the vacuum pump.

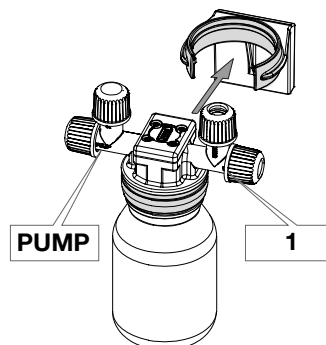

- ▶ Connect the instrument. See Chapter 5.7.1 "Connecting the vacuum pump", page 23.

5.7 Connecting vacuum

5.7.1 Connecting the vacuum pump

Precondition:

- The Woulff bottle is installed.
- The Interface I-80 / I-180 is installed.
- The vacuum pump is installed.
- ▶ Cut the hose to needed lengths.

Recommended hose lengths:

400 mm

(Condenser to Woulff bottle)

700 mm

(Interface I-80 / I-180 to Woulff bottle)

900 mm

(Vacuum pump to Woulff bottle)

- ▶ Install the vacuum hose onto the hose nipples.

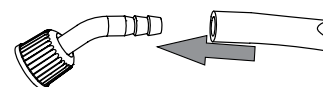

- ▶ Attach the hose to the condenser.

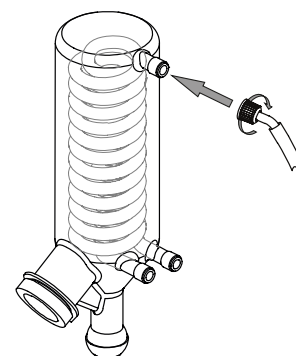

- ▶ Attach the hose to the Woulff bottle connection **1**.

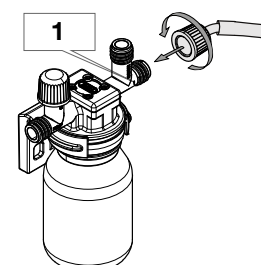

- ▶ Attach the hose to the Woulff bottle connection **PUMP**.

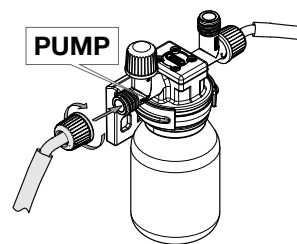

- ▶ Attach the hose to the vacuum pump connection **IN**.

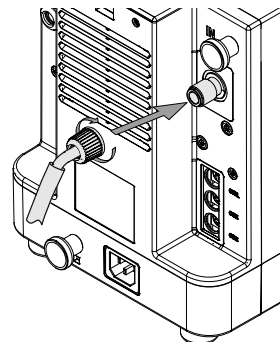

- ▶ Attach the hose to the Woulff bottle connection **CONTR**.

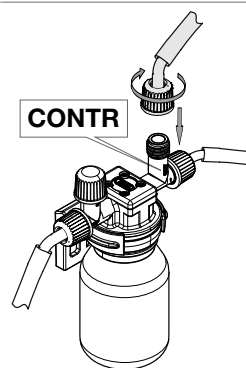

- ▶ Attach the hose to the Interface I-80 / I-180.

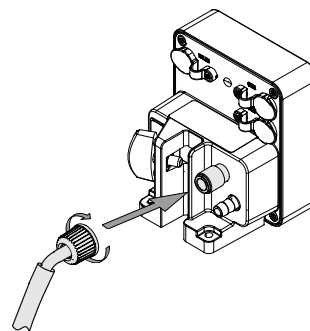

- ▶ Clamp the hoses through the fixtures.

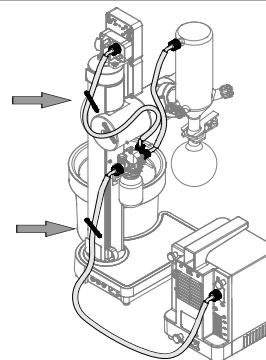

5.8 Connecting the cooling

Precondition:

- ☑ A chiller is installed or an in-house cooling system is available.

Recommended lengths:

1.5 m (Coolant hose 1)

1.5 m (Coolant hose 2)

- ▶ Cut the hose to needed lengths.
- ▶ Install the coolant hoses onto the hose nipples.
- ▶ Secure the coolant hoses in place with a hose clip.

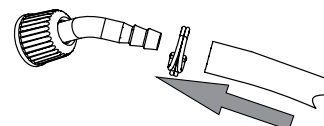

- ▶ Attach the coolant hoses to the condenser.

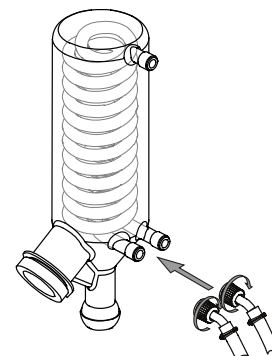

- ▶ Attach the coolant hoses to the Chiller/Cooling.

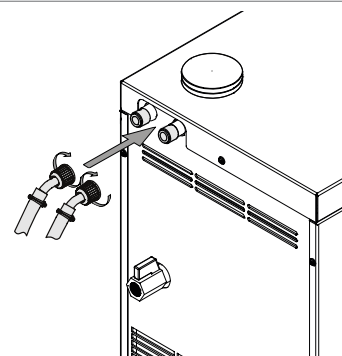

- ▶ Clamp the hoses through the fixtures.

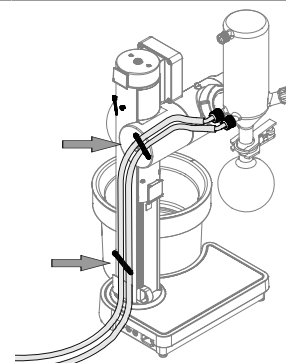

5.9 Accessories

5.9.1 Connecting the cooling water temperature sensor



NOTE

The cooling water temperature sensor allows to display the cooling temperature on the Rotavapor®, when using an in-house cooling system or a non BUCHI chiller.

- ▶ Cut the hose to needed lengths.

Recommended lengths:

1.5 m (Coolant hose 1)

1.5 m (Coolant hose 2)

- ▶ Install the coolant hoses onto the hose nipples.
- ▶ Secure the coolant hoses in place with a hose clip.

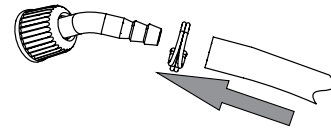

- ▶ Cut one coolant hose about 5 cm from the edge.
- ▶ Insert the sensor to the coolant hose.

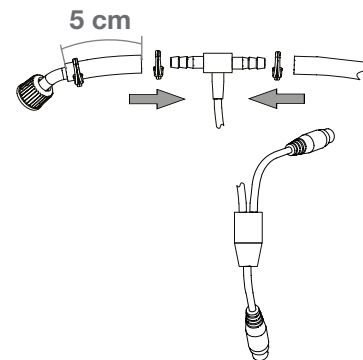

- ▶ Attach the coolant hoses to the condenser.
- ⇒ It is recommended to place the sensor close to the condenser, where the coolant flows into the condenser.

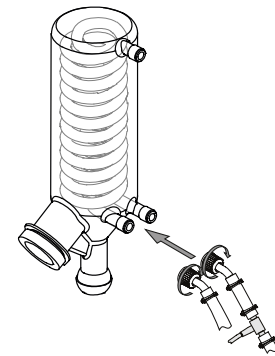

- ▶ Plug the sensor cable into the Rotavapor® connection **CW/T**.

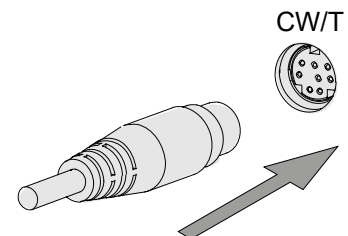

- ▶ Clamp the hoses through the fixtures.

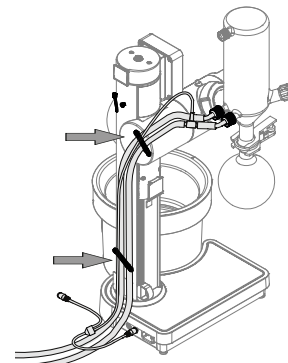

5.9.2 Connecting the cooling water valve

- ▶ Attach the cooling water valve to the available cooling water source.
- ▶ Connect the coolant hose with the cooling temperature sensor onto the cooling water valve.
- ▶ Connect the other coolant hose to a cooling water outflow.

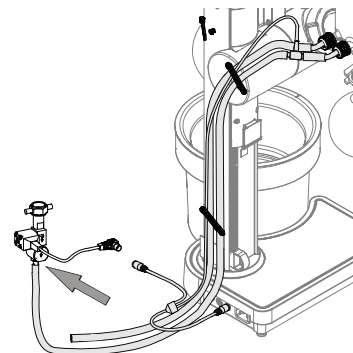

- ▶ Plug the cable from the cooling water valve into the available connection on the cooling water temperature sensor or to the Rotavapor® connection **CW/T**.

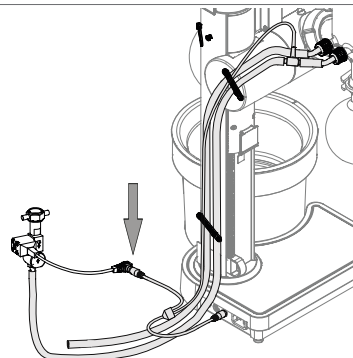

5.10 Securing against earthquakes

The instrument has an earthquake fixing point to protect the device against falling.

- ▶ Tie the lashing mount to a fixed point using strong cord or a wire.

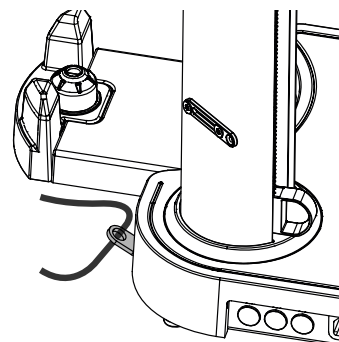

5.11 Establishing electrical connections



NOTICE

Risk of instrument damage because of not suitable power supply cables.

Not suitable power supply cables can cause bad performance or an instrument damage

- ▶ Use only BUCHI power supply cables.

Precondition:

- ☑ The electrical installation is as specified on the type plate.
 - ☑ The electrical installation is equipped with a proper grounding system.
 - ☑ The electrical installation is equipped with suitable fuses and electrical safety features.
 - ☑ The installation site is as specified in the technical data. See Chapter 3.5 "Technical data", page 16.
-
- ▶ Connect the power supply cable to the connection on the instrument. See Chapter 3.2 "Configuration", page 13.
-
- ▶ Connect the mains plug to an own mains outlet socket.
-

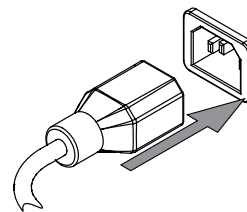

6 Interface

6.1 Configuration

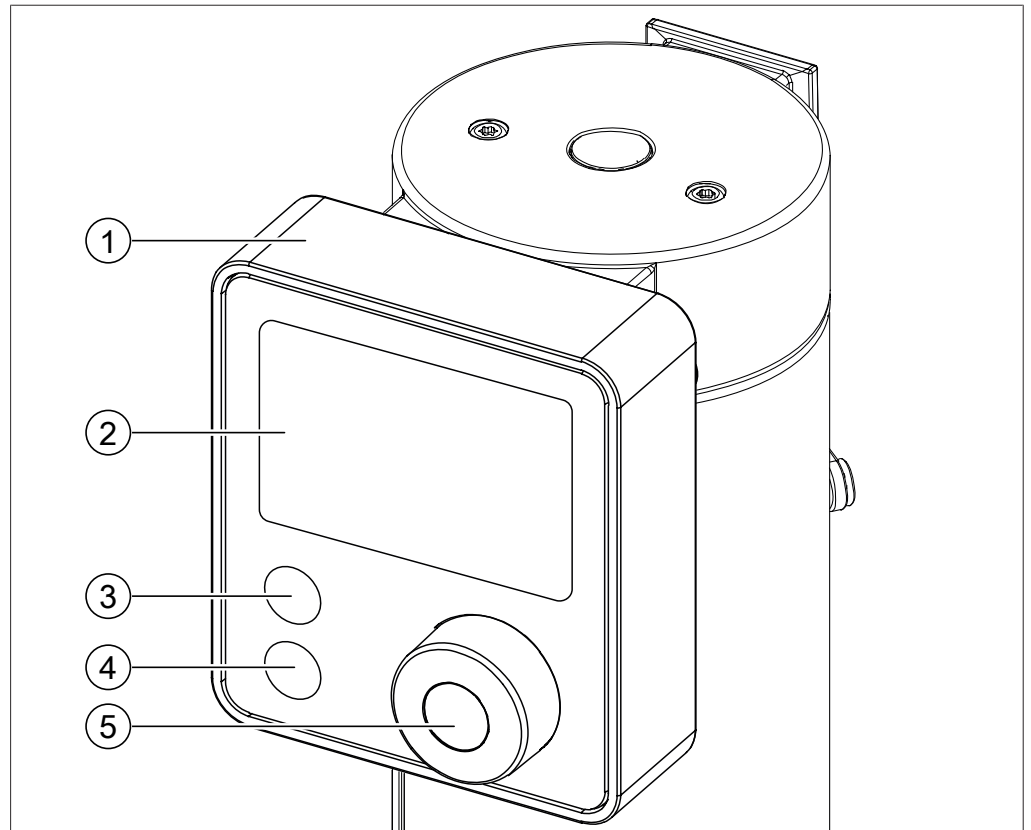





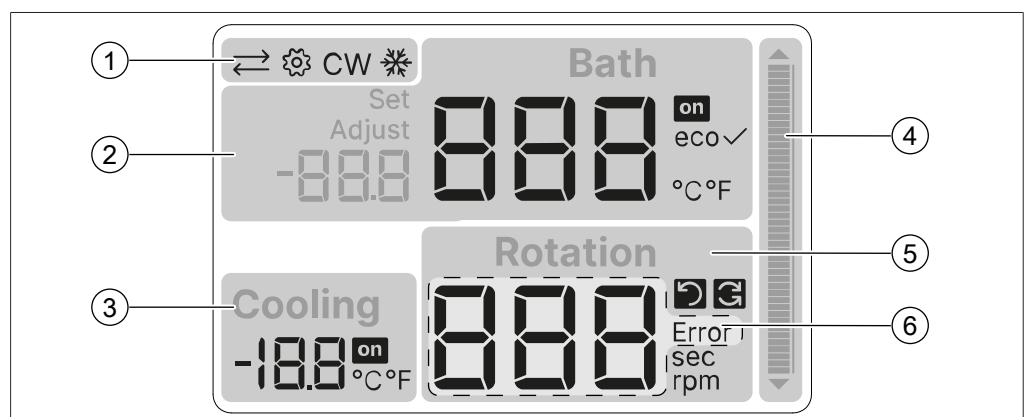

- | | |
|-----------------------------|----------------------|
| 1 Interface cover | 2 Display |
| 3 Button SET | 4 Button STOP |
| 5 <i>Navigation control</i> | |

6.2 Display layout



- | | |
|--------------------|-------------------------|
| 1 Status bar | 2 Heating bath control |
| 3 Cooling control | 4 Temperature indicator |
| 5 Rotation control | 6 Error code |

6.3 Display symbols

Symbol	Description
	BUCHI COM connected
	Settings
CW	Cooling water valve connection
	Cooling active
Set	Set value
Adjust	One point calibration value
	Heating/Cooling ON
eco	Eco mode active
	to activate Eco mode
	Rotation
	Rotation with changing direction (drying mode)
Error	Error occurrence
sec	Seconds
rpm	Revolutions per minute
°C	Degree Celsius
°F	Degree Fahrenheit

6.4 Main functions

6.4.1 Start/Stop heating and cooling

► Push the **navigation control**.

⇒ Activates the function.

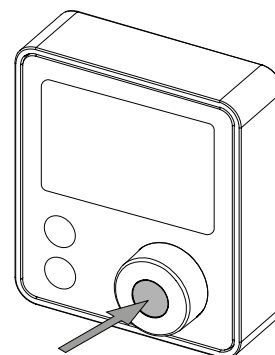

6.4.2 Control rotation speed

- ▶ Turn the *navigation control*.
- ⇒ Changes the symbol or value.

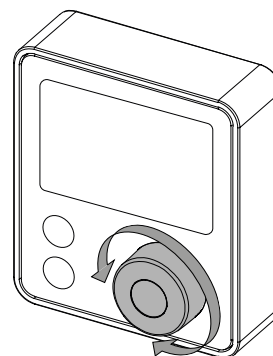

6.4.3 Stop the instrument

- ▶ Touch the **STOP** button.
- ⇒ Stops the instrument.

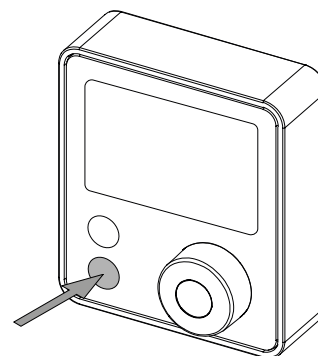

6.5 Settings

6.5.1 Operation settings

Navigation path

→  → Heating bath temperature → Cooling temperature (optional)

- ▶ Touch the **SET** button.
- ⇒ **Settings** symbol appears.
- ⇒ Blinking value is active.

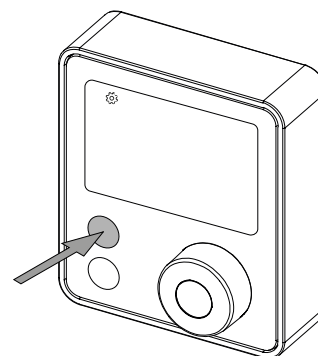

- ▶ Turn the **navigation control**.
- ⇒ Changes the value.

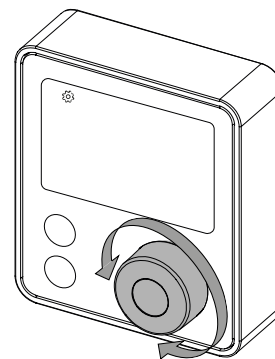

- ▶ Push the **navigation control**.
- ⇒ Exits the settings.

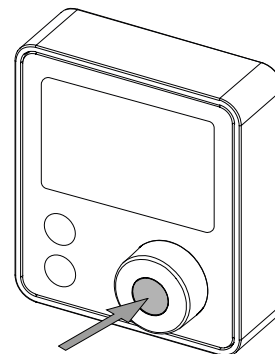



6.5.2 Setting to default settings

Precondition:

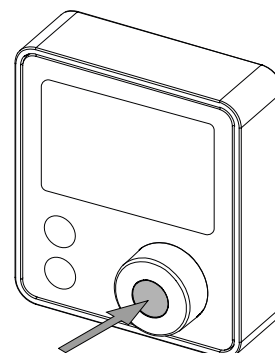
- Instrument is switched off.
- ▶ Press and hold the **navigation control**.
- ▶ Switch on the instrument.
- ▶ Wait until the indication bar is fully loaded.
- ⇒ Interface is reset to default settings.



6.6 Advanced settings

Navigation path	Symbol	Description
Rotation mode	 , 	Changing between one-directional and alternating rotation (drying mode, 15s interval).
Eco mode	eco	Activating eco mode to reduce power consumption. (Automatic heating off and reduction of display brightness when device not in use.)
Temperature unit	°C , °F	Changing temperature unit between °C and °F.
Heating bath temperature calibration	Adjust Bath	Setting an offset for the heating bath temperature calibration.
Cooling temperature calibration (optional)	Adjust Cooling	Setting an offset for the cooling temperature calibration.

- ▶ Touch the **SET** button and the **navigation control**.
- ⇒ **Settings** symbol appears.
- ⇒ Blinking symbol or value is active.

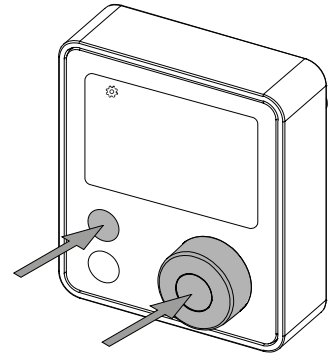

- ▶ Turn the **navigation control**.
- ⇒ Changes the symbol or value.

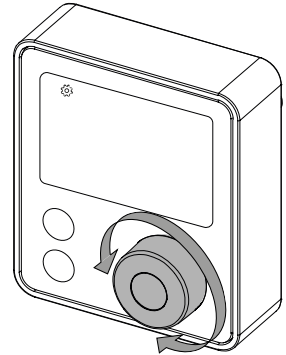

- ▶ Touch the **SET** button to navigate through the settings.

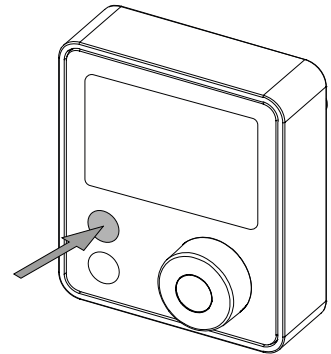

7 Operation

7.1 Preparing the heating bath



NOTE

It is recommended to use distilled or de-ionized water.

7.1.1 Filling the heating bath

NOTICE! Never overfill the heating bath. The maximum filling level is indicated in the graphic.

- ▶ Fill the heating bath with suitable fluid. See Chapter 3.5.1 "Rotavapor® R-80", page 16.
- ▶ Adjust filling height to the used glassware to avoid spillage.

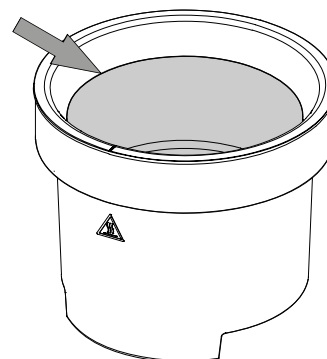

7.1.2 Positioning the heating bath

Precondition:

- Heating bath is filled with suitable fluid.
- ▶ Adjust the instrument base according to the glassware size.

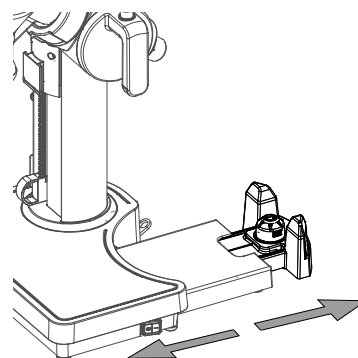

- ▶ Position the heating bath on the instrument base.

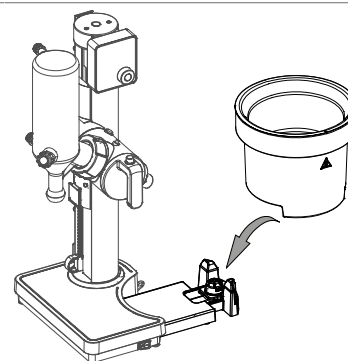

7.2 Attaching the evaporating flask



NOTICE

Risk of damage if fitted incorrectly

- ▶ When fitting the flask make sure that the edge of the glass does not collide with the vapor duct.
- ▶ Tighten the Combi-Clip hand-tight.

Precondition:

The rotary drive arm is in base position. (All the way up.)

▶ Fit evaporating flask to the vapor duct.

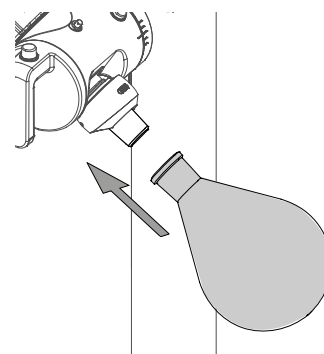

▶ Slide the Combi-Clip over the neck of the flask.

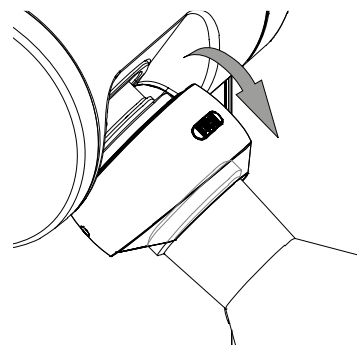

▶ Screw the Combi-Clip hand-tight.

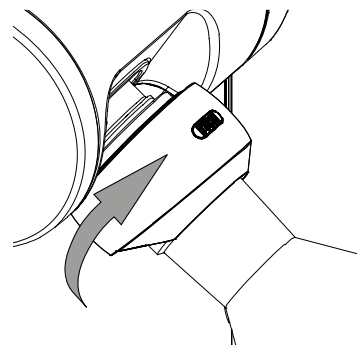

7.3 Attaching the receiving flask

Precondition:

The rotary drive arm is in base position. (All the way up.)

▶ Fit the receiving flask to the condenser.

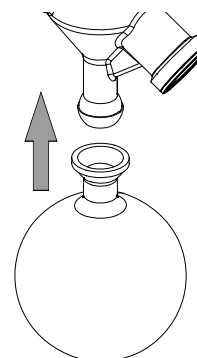

- ▶ Secure the receiving flask with the ball joint clamp.

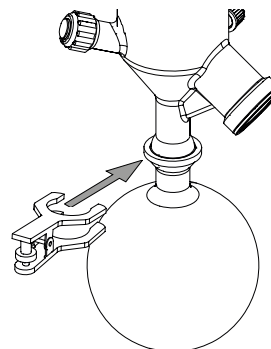

- ▶ Turn the wheel to secure the ball joint clamp.

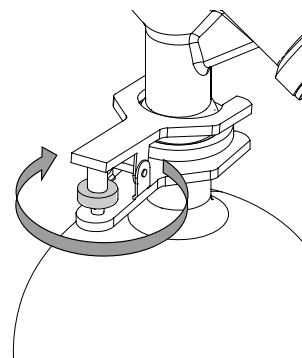

7.4 Adjusting immersion angle of evaporating flask

Precondition:

- The rotation is off.
 - The evaporating flask is installed.
 - The heating bath is in position.
 - ▶ Hold the condenser firmly with the left hand.
 - ▶ Push the angle adjustment button with the right hand.
 - ▶ Adjust the immersion angle.
 - ▶ Release the angle adjustment button, when the needed angle is reached.
- ⇒ The angle snaps into place with an audible click.
Angles between the drawn positions are not possible.

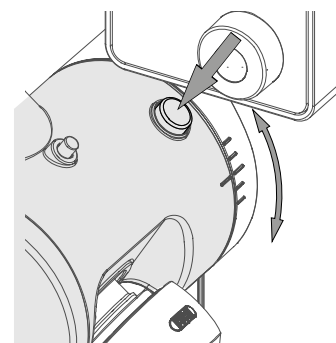

7.5 Adjusting immersion depth of evaporating flask



CAUTION

Risk of damage due to collision with the heating bath.

- ▶ Make sure that there is at least 5 mm clearance between the evaporating flask and the edge and/or bottom of the heating bath.

Precondition:

- ☑ The rotation is off.
- ☑ The evaporating flask is installed.
- ☑ The heating bath is in position.
- ☑ The immersion angle is adjusted.
- ▶ Hold the height adjustment handle.
- ▶ Push the height adjustment button.

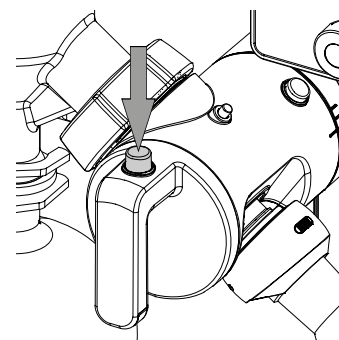

- ▶ Move the rotary drive arm up or down to adjust the height.
- ▶ Make sure that there is at least 5 mm clearance between the evaporating flask and the edge and/or bottom of the heating bath.
- ▶ Release the height adjustment button, when the needed height is reached.

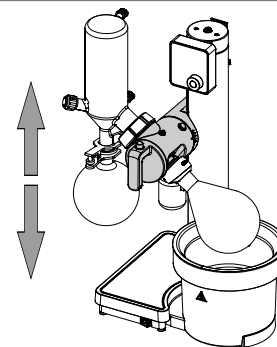

7.6 Using the height adjustment stopper

Precondition:

- ☑ The rotary drive arm is in base position. (All the way up.)
- ▶ Hold the height adjustment stopper as shown in the graphic.
- ▶ Install the height adjustment stopper through the notch in the toothed rack.

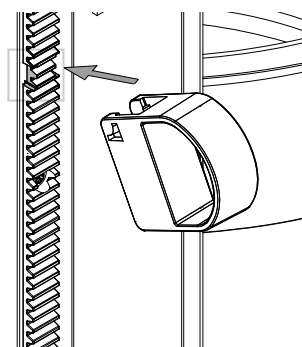

- ▶ Move the rotary drive arm to the desired lowest lift height.

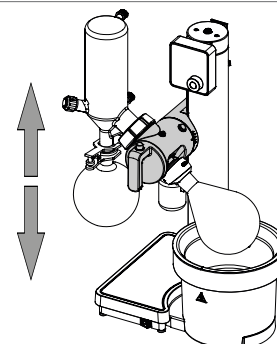

- ▶ Release the height adjustment stopper.

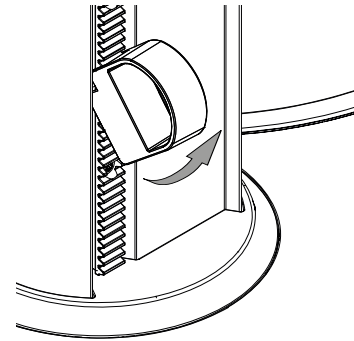

- ▶ Move the height adjustment stopper right below the rotary drive arm.

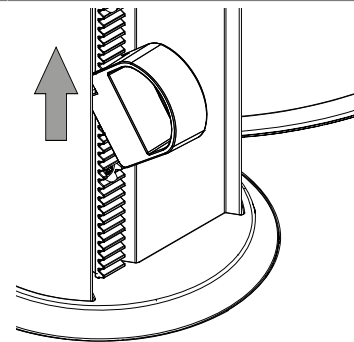

- ▶ Lock the position of the height adjustment stopper.

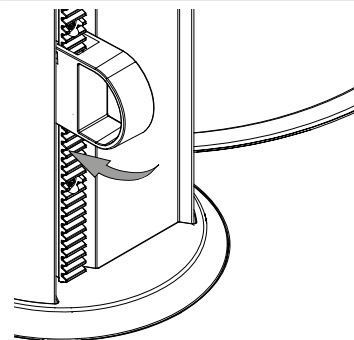

7.7 Performing a distillation process

Precondition:

- Installation is done.
- The receiving flask is installed.
- The evaporating flask is installed.
- The heating bath is filled and in position.
- The adjustments are done.
- The instrument is switched on.
- The settings are done.

- ▶ Push the **navigation control**.

- ⇒ The heating bath starts heating.
- ⇒ The temperature indicator is loading to the set temperature.

- ▶ Turn the **navigation control** for slow rotation.

- ⇒ The evaporating flask starts to rotate.

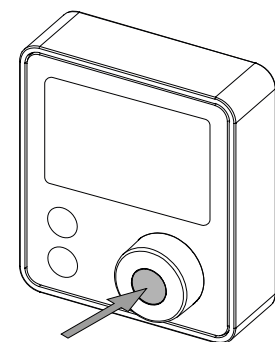

Rotation
888 rpm

- ▶ Start the vacuum. See additional manuals according to the instrument order code.



- ▶ Lower the rotary drive arm. See Chapter 7.5 "Adjusting immersion depth of evaporating flask", page 36.

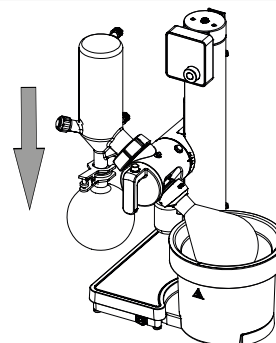

- ▶ Set rotation speed according to flask size and fill level.
- ⇒ Distillation process starts.

NOTICE! A higher rotation speed leads to a higher distillation rate.

Rotation
888 rpm

7.8 Performing a drying process

Precondition:

- The receiving flask is installed.
- The evaporating flask is installed.
- The heating bath is filled and in position.
- The adjustments are done.
- The instrument is switched on.
- The settings are done.

Rotation
888 sec

- ▶ Change the rotation mode to . See Chapter 6.6 "Advanced settings", page 32.
- ▶ Push the **navigation control**.
- ⇒ Exits the settings.

- ▶ Push the **navigation control**.
- ⇒ The heating bath starts heating.
- ⇒ The temperature indicator is loading to the set temperature.

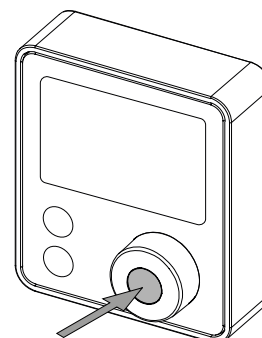

- ▶ Turn the **navigation control**.
- ⇒ The evaporating flask starts rotating.

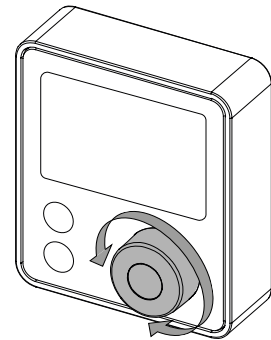

- ▶ Start the vacuum. See additional manuals according to the instrument order code.



- ▶ Lower the rotary drive arm. See Chapter 7.5 "Adjusting immersion depth of evaporating flask", page 36.

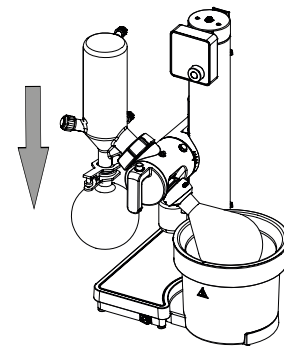

- ▶ Set the rotation speed according to flask size and fill level.
- ⇒ Drying process is finished, when the evaporating flask is solvent free.

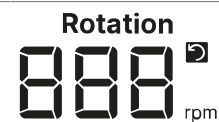

7.9 Aerating the system

Aeration with the aeration cap

- ▶ Turn the aeration cap on the Rotavapor® condenser.
- ⇒ System gets aerated.

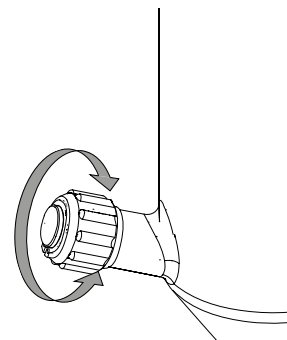

Aeration on the Interface I-80/I-180

- ▶ See additional manual according to purchase order.



7.10 Removing the evaporating flask



⚠ WARNING

Risk of skin burns due to hot glassware.

- ▶ Let the evaporating flask cool down.
- ▶ Wear suitable protective gloves.

Precondition:

- The Rotavapor® is aerated to ambient pressure.
- The evaporating flask stopped rotating.
- ▶ Move the rotary drive arm to base position.

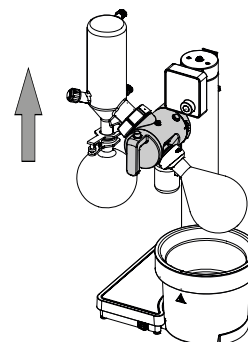

- ▶ Firmly hold the evaporating flask.
- ▶ Unscrew the Combi-Clip counter-clockwise until the evaporating flask ground glass joint is pushed off the vapor duct.

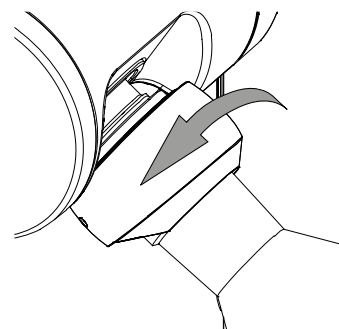

- ▶ Open the Combi-Clip to release the flask.

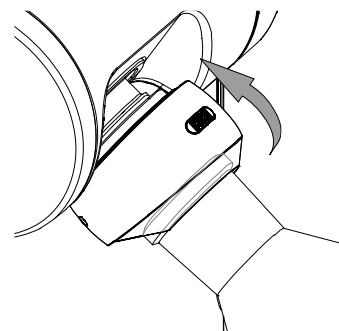

- ▶ Remove the evaporating flask from the vapor duct.

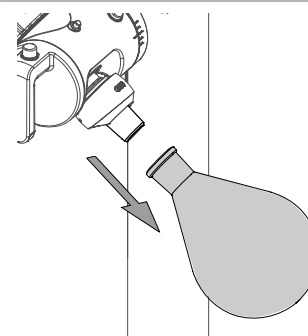

7.11 Removing the receiving flask

Precondition:

- ☑ The Rotavapor® is aerated to ambient pressure.
- ☑ The evaporating flask stopped rotating.
- ▶ Move the rotary drive arm to base position.

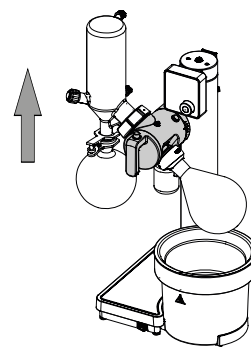

- ▶ Firmly hold the receiving flask.
- ▶ Release the ball joint clamp by turning the wheel counter-clockwise.

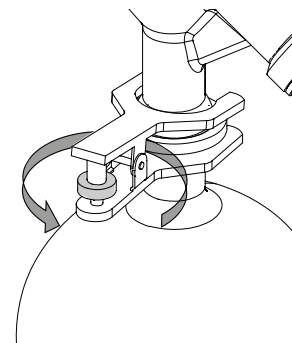

- ▶ Remove the ball joint clamp.

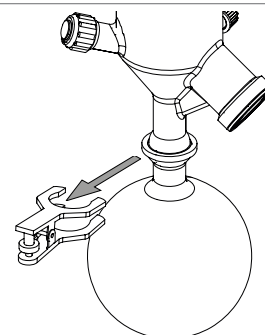

- ▶ Remove the receiving flask.

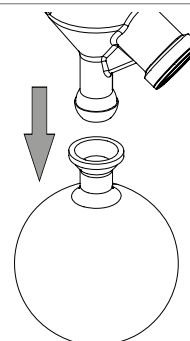

8 Cleaning and servicing



NOTE

- ▶ Carry out only the service and cleaning operations described in this section.
- ▶ Do not carry out any servicing and cleaning operations that involve opening the housing.
- ▶ Use only genuine BUCHI spare parts in order to ensure correct operation and preserve the warranty.
- ▶ Carry out the service and cleaning operations described in this section to extend the lifetime of the instrument.

8.1 Maintenance work

Action	Daily	Weekly	Yearly	Additional information
8.2 Removing solvent accumulations	1			before any extended period when the instrument is not used
8.3 Cleaning the housing		1		
8.4 Cleaning and servicing the warning and directive symbols		1		
8.5 Cleaning the heating bath		1		
8.6 Cleaning the condenser		1		
8.7 Cleaning the Woulff bottle		1		
8.10 Inspecting and cleaning the vapor duct		1		
8.11 Performing a leak test		1		
8.8 Inspecting and replacing the seals			1	1 or when system is leaking
8.9 Inspecting and replacing the hoses			1	1 or when system is leaking

1 - Operator

8.2 Removing solvent accumulations

Before any extended period in which the instrument is not used (e.g. overnight) all fluids must be removed.

Precondition:

- ☑ The vacuum pump is installed.
- ▶ Install a clean and dry receiving flask.
- ▶ Install a clean and dry evaporating flask.
- ▶ Make sure that all flasks are fitted well.
- ▶ Make sure that the aeration cap is closed.
- ▶ Connect the vacuum pump and evacuate the system as much as possible.
- ▶ Let the vacuum pump run for another 2 – 3 minutes.
- ▶ Aerate the instrument.
- ▶ Check if all solvent accumulations are removed.
- ▶ Dispose of solvent residues in accordance with the local regulations and statutory requirements.

8.3 Cleaning the housing

- ▶ Wipe down the housing with a damp cloth.
- ▶ If heavily soiled, use ethanol or a mild detergent.
- ▶ Wipe down the display with a damp cloth.

8.4 Cleaning and servicing the warning and directive symbols

- ▶ Check that the warning symbols on the instrument are legible.
- ▶ If they are dirty, clean them with a damp cloth.

8.5 Cleaning the heating bath

The inside of the heating bath should be cleaned regularly and at the latest if:

- the heating bath is contaminated
- limescale deposits start to form
- the stainless steel surface of the heating bath starts to rust

- ▶ Let the heating bath cool down.
- ▶ Remove the heating bath.
- ▶ Empty the heating bath.
- ▶ Remove small amounts of limescale using non-abrasive cleaners (e.g. household cleaner and washing-up sponge).
- ▶ Use acetic acid to dissolve stubborn limescale deposits.
- ▶ Rinse the heating bath thoroughly.

CAUTION! Do not immerse the heating bath in water.

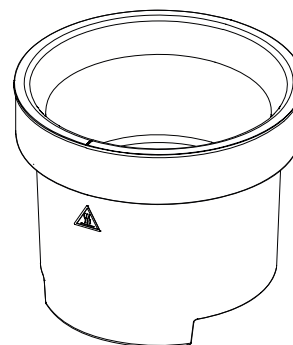

8.6 Cleaning the condenser

- ▶ Squirt ethanol with a wash bottle into the vacuum connection of the condenser.
- ▶ Rinse the ethanol out.
- ▶ Allow the ethanol to drain out at the bottom.
- ▶ Use an alkaline cleaning agent to remove stubborn dirt (e.g. algae).

8.7 Cleaning the Woulff bottle

- ▶ Unscrew the glass part of the Woulff bottle.
- ▶ Clean the glass part with ethanol to remove residues.
- ▶ Make sure that the seal is in place.
- ▶ Screw the glass part back into the Woulff bottle distributor cap.

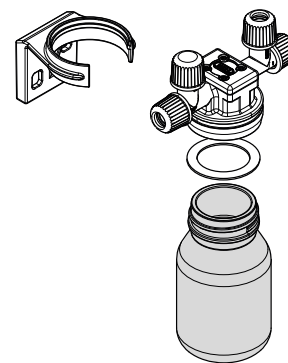

8.8 Inspecting and replacing the seals

- ▶ Remove the seals and inspect them for damages and cracks.
- ▶ Rinse the intact seals with water or ethanol.
- ▶ Dry the seals with a soft cloth.
- ▶ Replace damaged seals.
- ▶ Check the corresponding glass contact faces for damages (e.g. wear marks).

8.9 Inspecting and replacing the hoses

- ▶ Inspect the hoses for damages and cracks.
- ▶ Replace damaged hoses.

8.10 Inspecting and cleaning the vapor duct

- ▶ Remove the heating bath.
- ▶ Remove the evaporating flask.

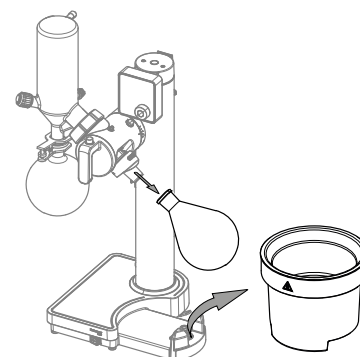

- ▶ Press the locking button.
- ▶ Firmly hold the vapor duct.
- ▶ Turn the Combi-Clip clockwise until the vapor duct is released.

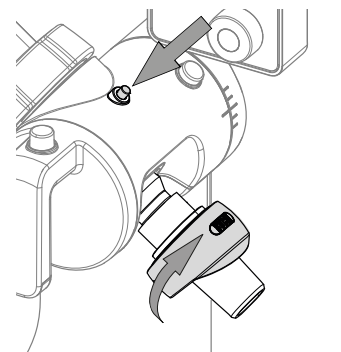

- ▶ Remove the vapor duct.
- ▶ Visually inspect the vapor duct for damages, wear marks and residues.
- ▶ Clean the vapor duct with a paper towel and water or ethanol.

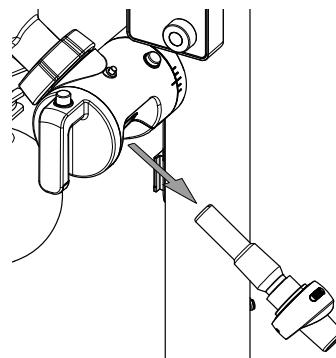

- ▶ Insert the vapor duct into the rotary drive unit.
- ⇒ The vapor duct snaps into place with an audible click.

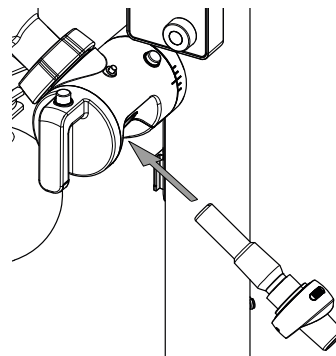

8.11 Performing a leak test

8.11.1 Performing a leak test manually

Precondition:

- The vacuum pump is installed.
- The system is dry.
- ▶ Install a dry 1 L receiving flask.
- ▶ Install a dry 1 L evaporating flask.
- ▶ Make sure that all flasks are fitted well.
- ▶ Make sure that the aeration cap is closed.

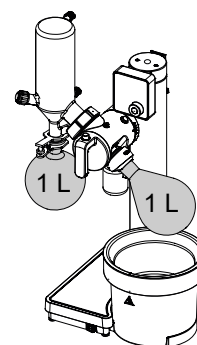

- ▶ Evacuate the system to a pressure of 50 mbar.
- ▶ Switch off the vacuum pump.
- ▶ Check the pressure after one minute.
- ⇒ If the pressure raised less than 5 mbar after one minute, the system is airtight.

If the system is not airtight.

- ▶ Check all seals. See Chapter 8.8 "Inspecting and replacing the seals", page 45
- ▶ Check all tubes. See Chapter 8.9 "Inspecting and replacing the hoses", page 45 .

8.11.2 Performing the leak test with the Interface I-180

Precondition:

- The Interface I-180 is installed.
- The vacuum pump is installed.
- The system is dry.
- ▶ Install a dry 1 L receiving flask.
- ▶ Install a dry 1 L evaporating flask.
- ▶ Make sure that all flasks are fitted well.
- ▶ Make sure that the aeration cap is closed.

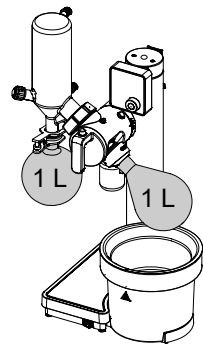

- ▶ Perform a leak test. See *Operation Manual Interface I-180*.



9 Help with faults

9.1 Troubleshooting

Problem	Possible cause	Action
Instrument is not working	No electrical connection	▶ Establish an electrical connection. See Chapter 5.11 "Establishing electrical connections", page 27.
	Main switch is off	▶ Switch on the main switch.
	Fuse is blown	▶ Replace the fuse. See Replacing the fuse. ▶ Contact BUCHI Customer Service.
Heating bath is not heating	Overheat safety cutout has tripped	▶ Reset the overheat safety cutout. See Chapter 9.2 "Resetting overheat safety cut-out", page 52. ▶ Replace the heating bath.
	Connector pins on the bottom side of the heating bath are dirty	▶ Clean the connector pins.
	Heating bath is damaged	▶ Replace the heating bath.
Cooling medium is leaking	Tube is leaking	▶ Replace the tubing. See Chapter 8.9 "Inspecting and replacing the hoses", page 45.
	Seal is damaged	▶ Replace the seals. See Chapter 8.8 "Inspecting and replacing the seals", page 45.
	Cooling connector is not tightend	▶ Check the cooling connection. See Chapter 5.8 "Connecting the cooling", page 25.

Problem	Possible cause	Action
Desired vacuum level is not reached	Back-evaporation from the receiving flask	▶ Empty the receiving flask. See Chapter 7.11 "Removing the receiving flask", page 42.
	Temperature difference between evaporating flask and condenser less than 20 °C	▶ Lower the set cooling temperature. See Chapter 6.5 "Settings", page 31.
	System is leaking	▶ Perform a leak test. See Chapter 8.11 "Performing a leak test", page 46. ▶ Service the vacuum pump. See <i>BUCHI Operation Manual Vacuum Pump</i> . ▶ Make sure that the needle valve on the side of the I-80 is closed. See <i>Operation Manual Interface I-80</i> .
	Vacuum pump is not running	▶ Switch on the main switch of the vacuum pump. ▶ See <i>Operation Manual Vacuum Pump V-80 / V-180</i> .
	Vacuum pump too weak	▶ Use suitably dimensioned vacuum pump.
Distillation is too slow	Vacuum level is not optimal for the application	▶ Lower pressure until distillation resumes. See Chapter 7.7 "Performing a distillation process", page 38. ▶ See <i>Operation Manual Interface I-180</i> . ▶ See <i>Operation Manual Interface I-80</i> .
	Temperature settings are not optimal for the application	▶ Check and adjust the temperatures of heating bath and coolant. See Chapter 7.1 "Preparing the heating bath", page 34 and <i>Operation Manual Chiller</i> . ▶ See Chapter 6.5.1 "Operation settings", page 31.
Height adjustment stopper does not block the moving rotary drive arm	Height adjustment stopper is mounted incorrectly	▶ See Chapter 7.6 "Using the height adjustment stopper", page 37.
No temperature reading from the heating bath	Heating bath is not well positioned on the connector	▶ Reposition the heating bath until it sits well on the connector.
	Connector pins on the bottom side of the heating bath are dirty	▶ Clean the connector pins.

9.1.1 Error codes

Error code	Description	Action
380	Motor does not run	▶ Contact BUCHI Customer Service.
385	Motor peak current too high	▶ Contact BUCHI Customer Service.
386	Motor steady current too high	▶ Make sure that the flask can rotate. ⇒ If the error code is still indicated. ▶ Contact BUCHI Customer Service.
388	Supply voltage too low	▶ Check the power supply. ⇒ If the error code is still indicated. ▶ Contact BUCHI Customer Service.
389	No reliable rotation measurement	▶ Contact BUCHI Customer Service.
390	Motor driver error	▶ Contact BUCHI Customer Service.
391	Cooling water valve driver error	▶ Contact BUCHI Customer Service.
450	Heating bath temperature increase too high	▶ Check the heating bath water level. See Chapter 7.1.1 "Filling the heating bath", page 34. ⇒ If the error code is still indicated. ▶ Contact BUCHI Customer Service.
480	Triac temperature >100°C	▶ Turn off the heating bath. ▶ Let the heating bath cool down. ⇒ If the error code is still indicated. ▶ Contact BUCHI Customer Service.
481	Heating bath is not heating	▶ Reset the overheat safety cut-out. See Chapter 9.2 "Resetting overheat safety cut-out", page 52. ⇒ If the error code is still indicated. ▶ Contact BUCHI Customer Service.
550	Heating bath temperature too high	▶ Check the heating bath water level. See Chapter 7.1.1 "Filling the heating bath", page 34. ⇒ If the error code is still indicated. ▶ Contact BUCHI Customer Service.
580	No valid heating bath temperature	▶ Check if the heating bath is in correct position. ▶ Check if the heating bath electrical contacts are clean. ⇒ If the error code is still indicated. ▶ Contact BUCHI Customer Service.
999	Initialization error	▶ Contact BUCHI Customer Service.

Error codes from connected BUCHI Recirculating Chiller

Error code	Description	Action
850	Coolant tank empty or level too low Pump malfunction	<ul style="list-style-type: none"> ▶ Switch off the instrument. ▶ Let the instrument cool down. ▶ Add the coolant fluid. ▶ Switch on the instrument. ⇒ If the error code is still indicated. ▶ Contact BUCHI Customer Service.
851	Temperature error	<ul style="list-style-type: none"> ▶ Switch off the instrument. ▶ Let the instrument cool down. ▶ Clean the air intake. ▶ Switch on the instrument. ⇒ If the error code is still indicated. ▶ Contact BUCHI Customer Service.
880	Defective temperature sensor	<ul style="list-style-type: none"> ▶ Switch off the instrument. ▶ Let the instrument cool down. ▶ Clean the air intake. ▶ Switch on the instrument. ⇒ If the error code is still indicated. ▶ Contact BUCHI Customer Service.
881	Compressor pressure fault	<ul style="list-style-type: none"> ▶ Switch off the instrument. ▶ Let the compressor cool down. ▶ Switch on the instrument. ⇒ If the error code is still indicated. ▶ Contact BUCHI Customer Service.
882	Electronic circuitry overheated	<ul style="list-style-type: none"> ▶ Switch off the instrument. ▶ Let the instrument cool down. ▶ Clean the air intake. ▶ Switch on the instrument. ⇒ If the error code is still indicated. ▶ Contact BUCHI Customer Service.

9.1.2 Customer service

Only authorized service personnel are allowed to perform repair work on the instrument which is not described in this manual. Authorization requires a comprehensive technical training and knowledge of possible dangers which might arise when working at the instrument. Such training and knowledge can only be provided by BUCHI.

The customer service and support offers the following support:

- Spare part delivery
- Repairs
- Technical advice

Addresses of official BUCHI customer service offices can be found on the BUCHI website.

www.buchi.com

9.2 Resetting overheat safety cut-out

- ▶ Let the heating bath cool down.
 - ▶ Remove the heating bath.
 - ▶ Empty the heating bath.
 - ▶ Press the reset button on the heating bath with a narrow object.
- ⇒ The overheat safety cut-out is reset.

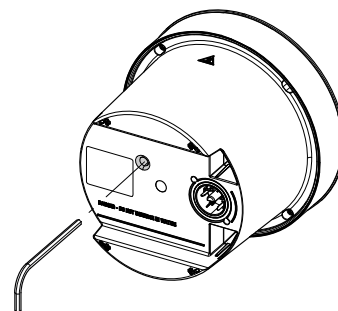

10 Taking out of service and disposal

10.1 Taking out of service

- ▶ Remove all solvents and coolants.
- ▶ Switch off the instrument and disconnect it from the mains power supply.
- ▶ Clean the instrument.
- ▶ Remove all tubing and communication cables from the device.

10.2 Disposal

The operator is responsible for proper disposal of the instrument.

- ▶ When disposing the equipment observe the local regulations and statutory requirements regarding waste disposal.
- ▶ When disposing, observe the disposal regulations of the materials used. For the used materials see Chapter 3.5 "Technical data", page 16 or the material labeling on the parts.

10.3 Returning the instrument

Before returning the instrument, contact the BÜCHI Labortechnik AG Service Department.

<https://www.buchi.com/contact>

11 Appendix

11.1 Spare parts and accessories



Use only genuine BUCHI consumables and spare parts in order to ensure correct, safe and reliable operation of the system.



NOTE

Any modifications of spare parts or assemblies are only allowed with the prior written permission of BUCHI.

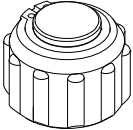
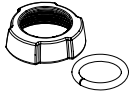
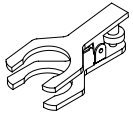
11.1.1 Spare parts

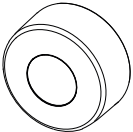
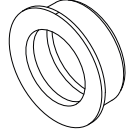
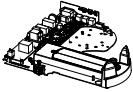
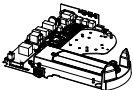
	Order no.	Image
Aeration cap	046574	
Flange nut with pressure spring	11062387	
Ball joint clamp. For BJ 35/20 To fasten receiving flask on condenser/secondary condenser.	003275	
Lid. For C condenser	11075812	
Drain sleeve, set 5 pcs.	028606	
Navigation control knob	11074581	
Sliding ring Encircles the installed vapor duct.	032005	
Base R-80 100 – 120 V, complete	11080626	
Base R-80 220 – 240 V, complete	11080627	

	Order no.	Image
Tower R-80, complete	11080628	
Interface R-80, complete	11080629	
Rotary drive arm R-80, complete	11080630	
Heating bath R-80 100 – 120 V, complete	11080631	
Heating bath R-80 220 – 240 V, complete	11080632	
Cable and tubing fixtures. Set. 3 pcs. Content: Rubber strips, screws	11080633	
Combi-Clip Combi-Clip with snap lock mechanism to fasten evaporating flask on vapor duct. Vapor duct not included.	11075539	
Beaker fastener, Connection with bayonet mount, for 500 mL For beaker flask 500 mL	11059810	
Sieve for cooling water valve, Ø18 mm	011514	
Woulff bottle holder	11075161	
Receiving vessel, GL 40, 125 mL, P+G For Woulff bottle	047233	
Fuses, set. 10 pcs. T 12.5A H 250V (100 – 120 V), 20 mm, Ø5 mm	047939	

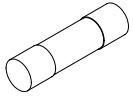

	Order no.	Image
Fuses, set. 10 pcs. T 6.3A H 250V (220 – 240 V), 20 mm, Ø5 mm	11075587	

11.1.2 Wear parts

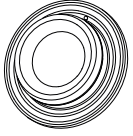

Vacuum seal

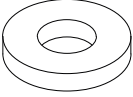
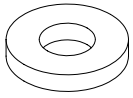
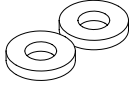
	Order no.	Image
Vacuum seal VS 22, PTFE base, NBR O-ring, FDA compliant	11075810	

Seals

	Order no.	Image
Seals, set. 10 pcs, for hose barbs GL 14, EPDM, black	040029	
Seals, set. 10 pcs, for hose barbs GL 14, FPM, green	040040	
Seals, set. 10 pcs, for hose barbs GL 14, silicone, red	040023	
Seal Woulff bottle	047165	

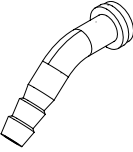
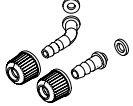
Hose barbs

	Order no.	Image
Hose barb, bent, GL 14, incl. silicone seal	018916	
Hose barbs, set. 2 pcs, bent (1), straight (1), GL 14, silicone seal Content: Hose barbs, cap nuts, seals	041939	
Hose barbs, set. 3 pcs, bent, GL 14, silicone seal Content: Hose barbs, seals.	041987	

	Order no.	Image
Hose barbs, set. 4 pcs, bent GL 14, silicone seal Content: Hose barbs, cap nuts, seals	037287	
Hose barbs, set. 4 pcs, bent, GL 14, EPDM seal Content: Hose barbs, cap nuts, seals.	043129	
Hose barbs, set. 4 pcs, bent, GL 14, FPM seal Content: Hose barbs, cap nuts, seals.	040295	
Hose barbs, set. 4 pcs, straight, GL 14, EPDM seal Content: Hose barbs, cap nuts, seals.	043128	
Hose barbs, set. 4 pcs, straight, GL 14, FPM seal Content: Hose barbs, cap nuts, seals.	040296	
Hose barbs, set. 4 pcs, straight, GL 14, silicone seal Content: Hose barbs, cap nuts, seals	037642	
Hose barbs, set. 6 pcs, bent (4), straight (2), GL 14, silicone seal Content: Hose barbs, cap nuts, seals.	038000	

Miscellaneous wear parts

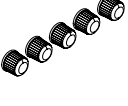
	Order no.	Image
Cap nuts, set. 10 pcs, screw cap with hole, GL 14	041956	
Screw caps, set. 5 pcs, closed with PTFE seal, GL 14	040624	

11.1.3 Glass parts

Condenser

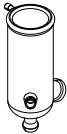

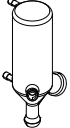

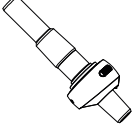
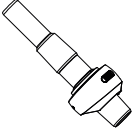

	Order no.	Image
Condenser C mini. Cold trap, 450 cm ² , 35° tilt angle, P+G-LT, incl. lid	11075732	

	Order no.	Image
Condenser V mini. Vertical condenser, 1280 cm ² , 35° tilt angle, P+G	11075730	

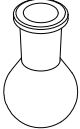
Vapor duct

	Order no.	Image
Vapor duct For V/C cond., Ø22 mm, SJ 24/40, incl. Combi-Clip	11075727	
Vapor duct For V/C cond., Ø22 mm, SJ 29/32, incl. Combi-Clip	11075728	

Evaporating flask

	Order no.	Image
Evaporating flask Glass, SJ 24/40, 50 mL	008750	
Evaporating flask Glass, SJ 24/40, 100 mL	008751	
Evaporating flask Glass, SJ 24/40, 250 mL	008754	
Evaporating flask Glass, SJ 24/40, 500 mL	008758	
Evaporating flask Glass, SJ 24/40, 1000 mL	000440	
Evaporating flask Glass, SJ 29/32, 50 mL	000431	
Evaporating flask Glass, SJ 29/32, 100 mL	000432	

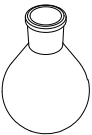
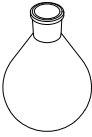
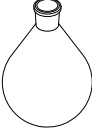
	Order no.	Image
Evaporating flask Glass, SJ 29/32, 250 mL	000433	
Evaporating flask Glass, SJ 29/32, 500 mL	000434	
Evaporating flask Glass, SJ 29/32, 1000 mL	000435	

Drying flask

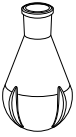
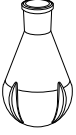
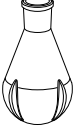
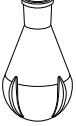
	Order no.	Image
Drying flask Glass, SJ 24/40, 500 mL With 4 indents for better mixing/drying.	011579	
Drying flask Glass, SJ 24/40, 1000 mL With 4 indents for better mixing/drying.	000420	
Drying flask Glass, SJ 29/32, 500 mL With 4 indents for better mixing/drying.	000452	
Drying flask Glass, SJ 29/32, 1000 mL With 4 indents for better mixing/drying.	000453	

Beaker flask

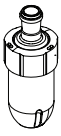
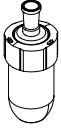
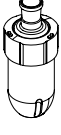

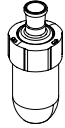
	Order no.	Image
Beaker flask, Drying, bayonet type, flat bottom, SJ 24/40, 500 mL Bayonet mount type Ø75 mm. With 4 indents for better mixing/drying. Working volume 150 mL. Content: 1 coupling piece, 1 seal, 1 flask and 1 beaker fastener.	11063159	
Beaker flask, Evap., bayonet type, flat bottom, SJ 24/40, 500 mL Bayonet mount type Ø75 mm. Working volume 150 mL. Content: 1 coupling piece, 1 seal, 1 flask and 1 beaker fastener.	11063155	
Beaker flask, Drying, bayonet type, flat bottom, SJ 29/32, 500 mL Bayonet mount type Ø75 mm. With 4 indents for better mixing/drying. Working volume 150 mL. Content: 1 coupling piece, 1 seal, 1 flask and 1 beaker fastener.	11063158	

	Order no.	Image
Beaker flask, Evap., bayonet type, flat bottom, SJ 29/32, 500 mL Bayonet mount type Ø75 mm. Working volume 150 mL. Content: 1 coupling piece, 1 seal, 1 flask and 1 beaker fastener.	11063154	

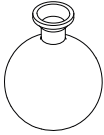
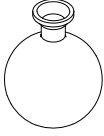
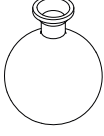
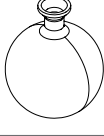
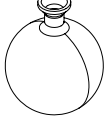

Receiving flask

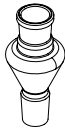
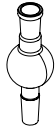
	Order no.	Image
Receiving flask Glass, BJ 35/20, 500 mL	000424	
Receiving flask Glass, BJ 35/20, 500 mL, P+G	025264	
Receiving flask Glass, BJ 35/20, 500 mL, P+G-LT Application temperature: -70 to 40 °C.	040774	
Receiving flask Glass, BJ 35/20, 1000 mL, P+G	020728	
Receiving flask Glass, BJ 35/20, 1000 mL, P+G-LT Application temperature: -70 to 40 °C.	040775	

Bump trap adapter

	Order no.	Image
Bump trap adapter Glass, Reitmeyer, SJ 24/40, 150 mm	036577	
Bump trap adapter Glass, SJ 24/40, 175 mm	11056919	
Bump trap adapter Glass, Reitmeyer, SJ 29/32, 135 mm	036576	
Bump trap adapter Glass, SJ 29/32, 160 mm	11056920	

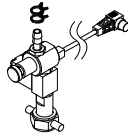
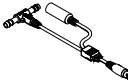
11.1.4 Accessories

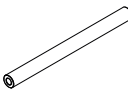
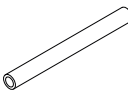
	Order no.	Image
<p>Woulff bottle, 125 mL, P+G, incl. holder</p> <p>For trapping particles and droplets and for pressure equalization.</p>	11075622	
<p>Cooling water valve, 24 VAC</p> <p>Valve opens cooling water feed during distillation.</p>	031356	
<p>Cooling water temperature sensor</p>	11075306	
<p>Flask holder, EPDM, slip free</p> <p>Holder for round-bottom flasks (50 – 5000 mL)</p>	048618	
<p>Flask holders, set. 5 pcs, EPDM, slip free</p> <p>Holder for round-bottom flasks (50 – 5000 mL)</p>	11059916	
<p>Heating bath balls, 450 pcs, PP, Ø10 mm</p> <p>To reduce energy consumption of heating bath and for less evaporation of the heating medium. For temperatures up to 100°C.</p>	036405	
<p>Tubing, synthetic rubber, Ø6/13 mm, black, per m</p> <p>Use: Vacuum</p>	11063244	
<p>Tubing, silicone, Ø6/9 mm, transparent, per m</p> <p>Use: Cooling media</p>	004133	



11594485 | A en

We are represented by more than 100 distribution partners worldwide.
Find your local representative at:

www.buchi.com

Quality in your hands
